



CITY OF PATASKALA

RESOLUTION 2019-059

Passed September 6, 2019

A RESOLUTION AUTHORIZING AND DIRECTING THE CITY ADMINISTRATOR TO EXECUTE AN AMENDED WATER SERVICE CONTRACT AND AN AMENDED SANITARY SEWER SERVICE CONTRACT WITH THE SOUTHWEST LICKING COMMUNITY WATER AND SEWER DISTRICT

WHEREAS, the City of Pataskala Utility Department operates and maintains a water distribution system as well as a sanitary sewer collection system; and

WHEREAS, the Southwest Licking Water and Sewer District also operates and maintains a water distribution system and a sanitary sewer collection system; and

WHEREAS, the City of Pataskala and the Southwest Licking Water and Sewer District currently operate under separate water and sewer service contracts. While these are separate contracts, they are inherently connected; and

WHEREAS, recently, the City and District began discussing changes to the terms of current agreements, including the service area map. All of the changes, which have been discussed, share on common goal – better service for water and sewer customers as the need for these services increases; and

WHEREAS, Council for the City of Pataskala would like to take this opportunity to amend the water service contract and sanitary sewer contract.

NOW THEREFORE BE IT RESOLVED BY THE COUNCIL OF THE CITY OF PATASKALA, COUNTY OF LICKING, STATE OF OHIO, A MAJORITY OF MEMBERS PRESENT CONCURRING THAT:

Section 1: Council for the City of Pataskala hereby authorizes and directs the City Administrator to execute an amended water service contract and an amended sanitary sewer service contract, with the Southwest Licking Community Water and Sewer District, copies of which are attached hereto as Exhibit A and Exhibit B and incorporated herein by reference.

Section 2: It is hereby found and determined that all formal actions of this Council concerning and relating to the passage of this Resolution were adopted in an open meeting of Council and that all deliberations of the Council and any of the decision-making bodies of the City of Pataskala which resulted in such formal actions were in

Section 4: This Resolution shall take effect at the earliest time allowed by the Charter of the City of Pataskala.

ATTEST:



Kathy M. Hoskinson, Clerk



Michael W. Compton, Mayor

APPROVED AS TO FORM:

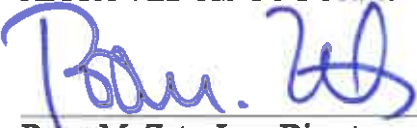

Brian M. Zets, Law Director

Exhibit A

AMENDED WATER SERVICE CONTRACT
BETWEEN
THE CITY OF PATASKALA, OHIO
AND
SOUTHWEST LICKING COMMUNITY
WATER AND SEWER DISTRICT

THIS AMENDED CONTRACT, made and entered on the date last executed below, by and between the City of Pataskala, an Ohio municipal corporation (the "City"), pursuant to the authority granted under Resolution No. 2019-059 by the Council for the City of Pataskala, and Southwest Licking Community Water and Sewer District (the "District"), a political subdivision established pursuant to R.C. Chapter 6119, pursuant to Resolution No. _____ by the District Board of Trustees. City and District are individually referred to as "Party" and collectively referred to as the "Parties."

WITNESSETH:

WHEREAS, the City and District previously entered into a Water Service Contract on or about September 1, 2004 (the "Original Contract"); and

WHEREAS, the City and District now desire to enter into an amendment to such contract (the "Amended Contract"), providing for Water Services within the corporate limits of the City and areas within the District, which overlap such corporate limits; as well as setting forth their respective obligations regarding Service Areas and Operational Support Connections.

NOW, THEREFORE, in consideration of the foregoing, and the mutual covenants and agreements set forth herein, the City and District agree as follows:

1. **Definition of "Project"**. The term "Project" as used hereinafter shall have the same definition as the term "water resource project" defined in R.C. 6119.011(G).

2. **Designation of Service Areas.** The City and District agree that the Service Areas described herein on Exhibit A, attached hereto and incorporated herein by reference, designates the Service Area of each Party.
3. **Provision of Services.** Except as provided herein, the Parties agree that only the Party in whose Service Area a property is located will be permitted to provide service to that property, except those properties already receiving service from either Party on the date of the execution of this Amended Contract.
4. **Bases for Designated Service Areas.**
 - A. The Parties specifically acknowledge and agree the Service Areas delineated herein are based upon sound engineering principles, existing infrastructure, future raw water resources, pressure zone capabilities, as well as the ability to provide service.
 - B. The Parties further agree the Service Areas designated in Exhibit A have been developed utilizing sound engineering practices and principles, and therefore meet the requirements of the "feasible and economical" language contained in the merger document approved by the City and Lima Township voters at the time a vote on the merger of the two entities occurred. Potential shared service areas constitute predominantly future commercial and/or industrial developments where service by the Parties could potentially be more "feasible and economical" than either one or other Party attempting to service it alone, depending upon the capabilities necessary for these future developments.
5. **Definition of Operational Support Interconnect.** An Operational Support Interconnect ("the Interconnect") is an interconnection that may be utilized to assist in, or avoid difficulties with, operational aspects of either Parties' treatment and/or distribution

systems, or due to any situation arising from fire, flood, drought, storm, interruption of power supply, breakdown of a water system, or other unforeseen natural or man-made circumstance that causes, or will likely cause a loss of potable condition of water in all or part of a party's water system.

6. **Denial of Service.** The Parties agree that either Party may deny service, on a case by case basis, to a potential user in its own Service Area for any reason, then offer the right to the other Party to provide such services, provided that the denying Party has supplied such denial and subsequent offered assignment in written form. The receiving Party must provide to the offering Party a decision in written form on their desire to accept or deny the opportunity to service the denied area within 60 days of the offering Party's written denial of service. Once this assignment is effective, Exhibit A will be amended to show an accurate depiction of the service area.
7. **Inquiry Regarding Service.** If an inquiry regarding service is received by the Party in whose area the property requesting service is not located, that Party shall promptly refer the inquiries to the other Party.
8. **Watkins Road Wellfield.** The Parties agree the City may extend services from the Watkins Road wellfield to unincorporated areas only if there is documented dewatering of adjacent wells as a direct and actual result of the Watkins Road wellfield activity.
9. **Meter Readings.** Each Party shall share with the other, at no cost, on a monthly basis water consumption reading for their water-only customers to whom the other Party is providing sewer services. The Parties agree to cooperate in analyzing their own and the other's billing systems to determine the most efficient method of transferring data. Transfer of data may be by electronic or paper transfer.

10. **Fannin and Deagle Properties.** Notwithstanding anything in the Amended Contract to the contrary, the rights to provide water service to the Fannin and Deagle Properties, identified in Exhibit C, will belong to the City at the effective date of this Amended Contract.

11. **Columbia Road Properties.** Notwithstanding anything in the Amended Contract to the contrary, the rights to provide water service to the Columbia Road Properties, identified in Exhibit C, will belong to the District at the effective date of this Amended Contract.

12. **Scotland Ridge Properties.** Notwithstanding anything in this Amended Contract to the contrary, as soon as the Scotland Ridge Phase 2 begins to develop, the District shall collect all new tap fees, have ownership of, and be solely responsible for maintaining all infrastructure and/or facilities related to Scotland Ridge Phase 2. However, the City shall provide water service through its infrastructure to Scotland Ridge Phase 2 from the date such service is requested until the District has installed a service line at the boundary of Scotland Ridge Phase 2 and can begin providing service. The District will provide meter readings to the City pursuant to section 9 above, so that the City may bill the customers in Scotland Ridge Phase 2 for the water consumption.

Once the District begins servicing Scotland Ridge Phase 2:

- (1) ownership of all the public water service improvements, infrastructure, and/or facilities for all phases of Scotland Ridge, identified in Exhibit C, shall be transferred and conveyed from the City to the District, including transfer of easements and facilities by duly executed Bills of Sale; and
- (2) the City will retain the tap fees it collected from Phase 1 of Scotland Ridge prior to commencement of services by the District to Phase 2; and

- (3) upon commencement of the provision of services by the District to Phase 2, the City will thereafter no longer have a duty to repair, replace, or otherwise maintain any improvements, infrastructure, and/or facilities for all phases of Scotland Ridge, and the District shall thereafter have responsibility for the same; and
- (4) the City shall discontinue providing water services to any customers located in any phase of Scotland Ridge and thereafter will cease and desist from invoicing these customers, which such customers shall thereupon become customers of the District.

13. **Highland Estates and State Route 310 Properties.** Notwithstanding anything to the contrary in this Amended Contract, once the District has installed a service line at or near the boundary of Scotland Ridge, Phase 2 and can begin providing service, the District shall provide service to the Highland Estates and State Route 310 Properties, identified in Exhibit C.

Once the District begins servicing the Highland Estates and State Route 310 Properties:

- (1) ownership of all the public water service improvements, infrastructure, and/or facilities, located on these parcels, shall be transferred and conveyed from the City to the District, including transfer of easements and facilities by duly executed Bills of Sale; and
- (2) the City will retain the existing tap fees it collected for these properties prior to the commencement of service by the District; and
- (3) upon commencement of the provision of services by the District, the City will thereafter no longer have a duty to repair, replace, or otherwise maintain such improvements, infrastructure, and/or facilities, and the District shall thereafter have responsibility for the same; and

(4) the City shall discontinue providing water services to any customers located in the Highland Estates and State Route 310 Properties and will cease and desist from invoicing these customers, which such customers shall thereupon become customers of the District.

14. State Route 310 Interconnection.

- A. Once the District starts servicing Scotland Ridge Phase 2 and the Highland Estates and State Route 310 Properties, the previously existing City infrastructure between the Highland Hills and Beechwood Trails subdivisions will serve as a location for interconnection between the District and the City Infrastructure. Within three (3) months of receiving notice in written form that the District is able to provide water service to the Scotland Ridge Phase 2, Highland Estates and State Route 310 Properties, the engineering of the State Route 310 Interconnection will commence in accordance with section 14B below. Construction of the State Route 310 Interconnection will be completed within 6 months following the approval of the engineering plan, barring conditions outside of the control of the Parties, including but not limited to, strikes, war, riot, weather conditions, or acts of God.
- B. The City and District shall work cooperatively and shall equally split all engineering and construction costs associated with designing and constructing the Interconnect. The City shall engage the services of a professional design engineer to perform an engineering evaluation to determine the exact requirements, specifications, and available service for the Interconnect. The selected professional design engineer must be acceptable to the District. The cost of the design engineering will be paid by the City, with 50% of the cost being reimbursed by the District. It is anticipated the

Interconnect shall contain a meter from each party, a directional check valve from each Party, two gate valves from each Party and a bypass gate valve as shown on the concept schematic that is attached hereto as Exhibit B and incorporated herein by reference. Thereafter, upon approval by both Parties of such design plan, the City shall commission the construction of such Interconnect, with 50% of the cost being reimbursed by the District.

- C. The Parties shall act, in accordance with Ohio law, to oversee all aspects of project development and construction, including, but not limited to, the selection of a design engineer, the development of design plans and construction specifications, the solicitation of competitive bids, and the construction of the Interconnect.
- F. Any repairs required to the meter pit, bypass line, bypass valve, fittings, pipe or any other shared infrastructure included with the Interconnect shall be equally split between the Parties.
- G. Each Party agrees to have the water meter on their side of the Interconnect inspected and calibrated by an independent professional consultant at the request of the other Party. If the meter is found to be within the accuracy range specified by the manufacturer, all costs incurred for the calibration process will be the responsibility of the requesting Party.
- H. Water usage by the Party receiving water service thru the Interconnect shall be determined based upon the providing Party's meter. The rate used will be the lowest of the two Parties' at the time the Interconnect is utilized, unless the Interconnect is being activated under subsection K of section 14. Each Party shall be responsible for reading the meter on its side of the meter pit. Neither Party shall charge the other a surcharge

or minimum fee for water used. During the next standard billing cycle following the date on which the meters are read, the providing Party shall invoice the receiving Party for the amount of water used. The Party receiving such invoice shall pay the amount shown within thirty (30) days of receipt, provided, however, that the rate for such services shall be the lowest rate as set forth above.

- I. In the event of a billing dispute, the receiving Party agrees to pay the undisputed amount billed until such time as the dispute is resolved. The receiving Party also will pay into an escrow account the disputed amount, where it will remain until the dispute is settled or resolved. In the event of a faulty meter, the Parties agree to use an estimate based on the difference between the providing Party's daily production average for the previous 30 days and the production for the days that the Interconnect was in use.
- J. If the Parties agree to utilize the State Route 310 Interconnection as an Operational Support Interconnect, the District shall contact the City's Utilities Director or other authorized representative and the City shall contact the District's General Manager or other authorized representative prior to services being utilized.
- K. If the Parties agree to utilize the State Route 310 Interconnection for the sale and purchase of bulk water to be used for any purpose, approval must be authorized by legislation from both the Council for the City of Pataskala and the Southwest Licking Community Water and Sewer District. This legislation must outline the timeframe, amount of bulk water, and the rate being charged for the bulk water. If the Parties cannot agree on the timeframe, amount of bulk water, and/or the rate being charged for the bulk water, the Interconnect will not be used for the sale and purchase of bulk water. The Parties' failure to agree on the timeframe, amount of bulk water, and/or the rate

being charged for the bulk water shall not be considered a dispute, and therefore will not be subject to the Resolution of Disputes procedure defined in Section 15.

- L. If the providing Party determines in its own discretion that it does not have excess capacity during the use of the Interconnect, it may refuse or restrict the supply to the receiving Party without prior notice. Notice shall be given to the receiving Party as soon as practically possible.
- M. The receiving Party is to use water received through the Interconnect ONLY for supplying water to its current customers, not to any other water utility company or non-customer user, unless the Interconnect is used for bulk water sales as set forth in subsection K of section 14 above.
- N. The providing Party agrees to provide potable water at the point of the Interconnect's master meter which complies with all applicable federal and state regulations. The Parties are not responsible for the quality of water provided after the Interconnect's meter to respective customers. Each Party reserves the right to add or delete any chemicals in its own production and distribution system which it believes are necessary or appropriate to provide safe, potable water.

15. Termination/Resolution of Disputes.

- A. If either Party is unable to obtain the necessary permits and approvals for any construction activity required by this Amended Contract, or the Parties cannot complete such construction activity due to shortage of labor or materials, strikes, war, riot, weather conditions, governmental rules, regulations or orders, including orders, judgments of any court, arbitration panel, tribunal, or administrative agency, acts of God, or conditions beyond the control of either Party, the Party which cannot perform

shall notify the other Party immediately upon learning it cannot perform according to the terms of this Amended Contract. The Party receiving notice shall then be entitled at its own discretion to terminate this Amended Contract or attempt to renegotiate the terms of the Amended Contract.

B. If a dispute arises under this Amended Contract, the Parties shall first attempt to resolve the dispute through mediation. Each Party shall bear its own cost/expense of mediation, including its proportionate share of the compensation and administrative expenses required by the mediator. The mediator shall be selected by the agreement of the Parties. If after 30 days, the Parties cannot agree on a mediator, the Party who is requesting mediation shall choose the mediator. If the dispute is not resolved in mediation, a Party may commence a lawsuit seeking specific performance of this Amended Contract, civil damages, costs, expenses, and any other relief and/or remedy available in law and/or equity.

16. **Term of Agreement/Renewal.** This Amended Contract is effective on the date last executed below and will continue for a twenty-five (25) year term, subject to an automatic renewal for an additional twenty-five (25) years, unless written notice is given by one Party to the other, on or before two (2) years prior to the end of the initial twenty-five (25) year term.

17. **Review of Amended Contract.** This Amended Contract shall be reviewed by the Parties jointly as often as the Parties deem necessary during the term of the Amended Contract and any renewal term for the sole purpose of reviewing, revising, amending, or modifying current and future service areas in addition to review and confirmation of the District's infrastructure improvements within the corporate limits of the City. Both Parties

recommend a joint review of this Amended Contract be conducted every five (5) years for the same stated purpose.

18. **Notices.** All notices, requests, and other communications ("Notice") to be given under this Amended Contract shall be in written form and shall be deemed to have been given, served, or made if transmitted by: certified mail, return receipt requested; common overnight carrier with delivery confirmation; facsimile with delivery conformation; or via email with delivery confirmation to the party to be notified as follows:

If to City: Pataskala Utilities Director

With copy to: City Administrator and Law Director

If to District: District General Manager

With copy to: District Board and District Attorney

19. **Entire Amended Contract/Modification.** This Amended Contract contains the entire agreement of the Parties with respect to this subject matter, and no amendment, modification, or waiver of any provision shall be valid unless in writing and signed by the Parties. The Parties may agree, in writing, to terminate this Amended Contract. This Amended Contract supersedes all prior discussions, agreements and undertakings of any kind between the Parties with respect to the subject matter of this Amended Contract, or any particular contained therein.

20. **Assignment.** This Amended Contract is not assignable or transferable without the express written consent of the Parties.

21. **Binding Effect.** This Amended Contract shall be binding on, and insure to the benefit of, the Parties and their heirs, personal representatives, successors, and assigns, except as otherwise provided in this Amended Contract.

22. **Governing Law.** This Amended Contract and the legal relations between the Parties shall be governed by and construed in accordance with the laws of the State of Ohio.
23. **Waiver.** The waiver by any Party to this Amended Contract of a breach of any provision of this Amended Contract shall not be deemed a continuing waiver or a waiver of any subsequent breach of that or any other duty provision of this Amended Contract.
24. **Counterparts.** This Amended Contract may be executed by facsimile or email and in multiple counterparts by the Parties, and the counterparts shall collectively constitute a single, original, document, notwithstanding the fact that the signatures may not appear on the same page.
25. **Invalidity.** Should any provision of this Amended Contract be declared or determined to be null, void, inoperative, illegal, or invalid for any reason, the validity of the remaining parts, terms, or provisions shall not be affected thereby and they shall retain their full force and effect, and said null, void, inoperative, illegal or invalid part, term, or provision shall be deemed not to be a part of this Amended Contract.

IN WITNESS WHEREOF, the Parties have caused this Agreement to be executed by their duly authorized officers on the dates appearing below.

CITY OF PATASKALA

**SOUTHWEST LICKING COMMUNITY
WATER AND SEWER DISTRICT**

By: _____
Its: _____

By: _____
Its: _____

Date: _____

Date: _____

APPROVED AS TO FORM:

Brian M. Zets, Law Director

APPROVED AS TO FORM:

John B. Albers, District Attorney

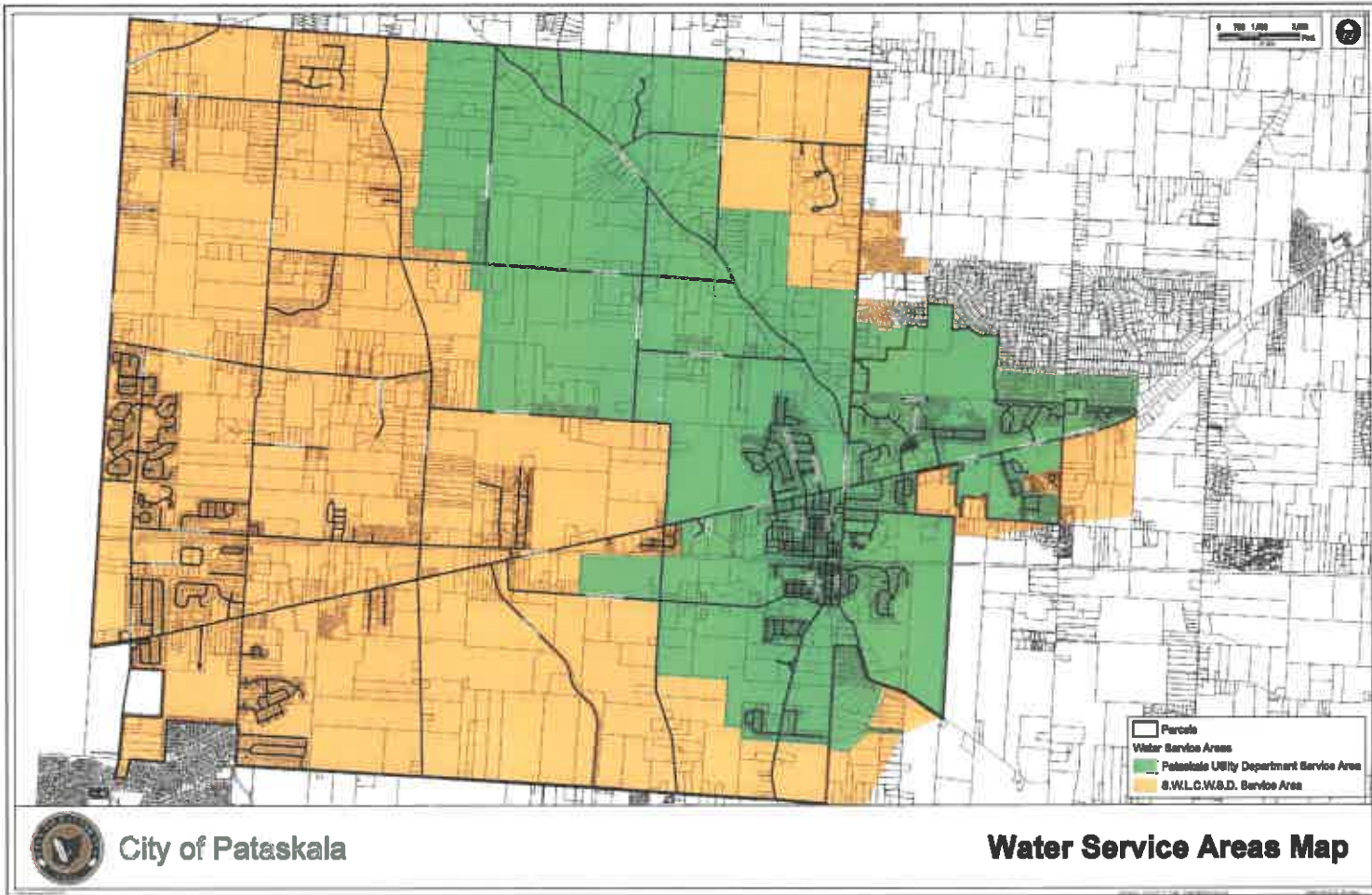

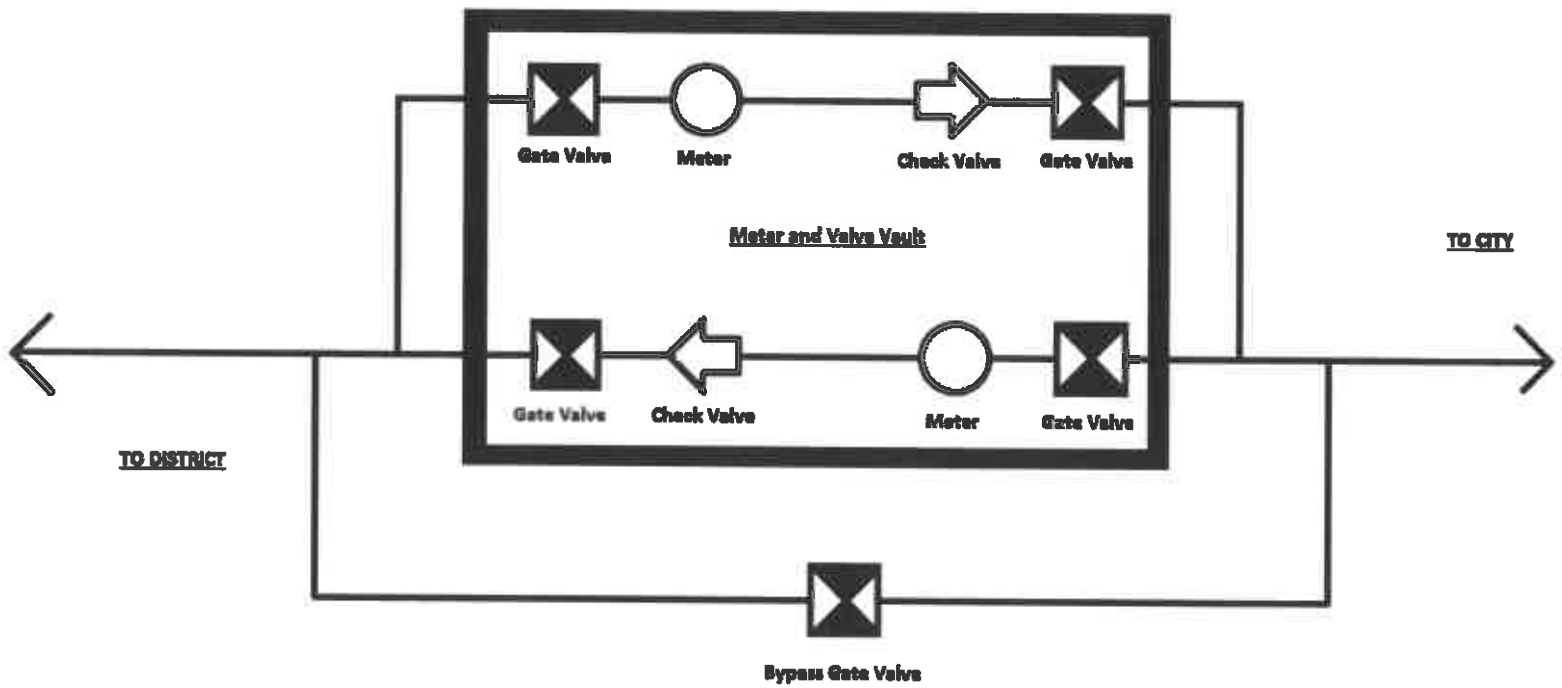
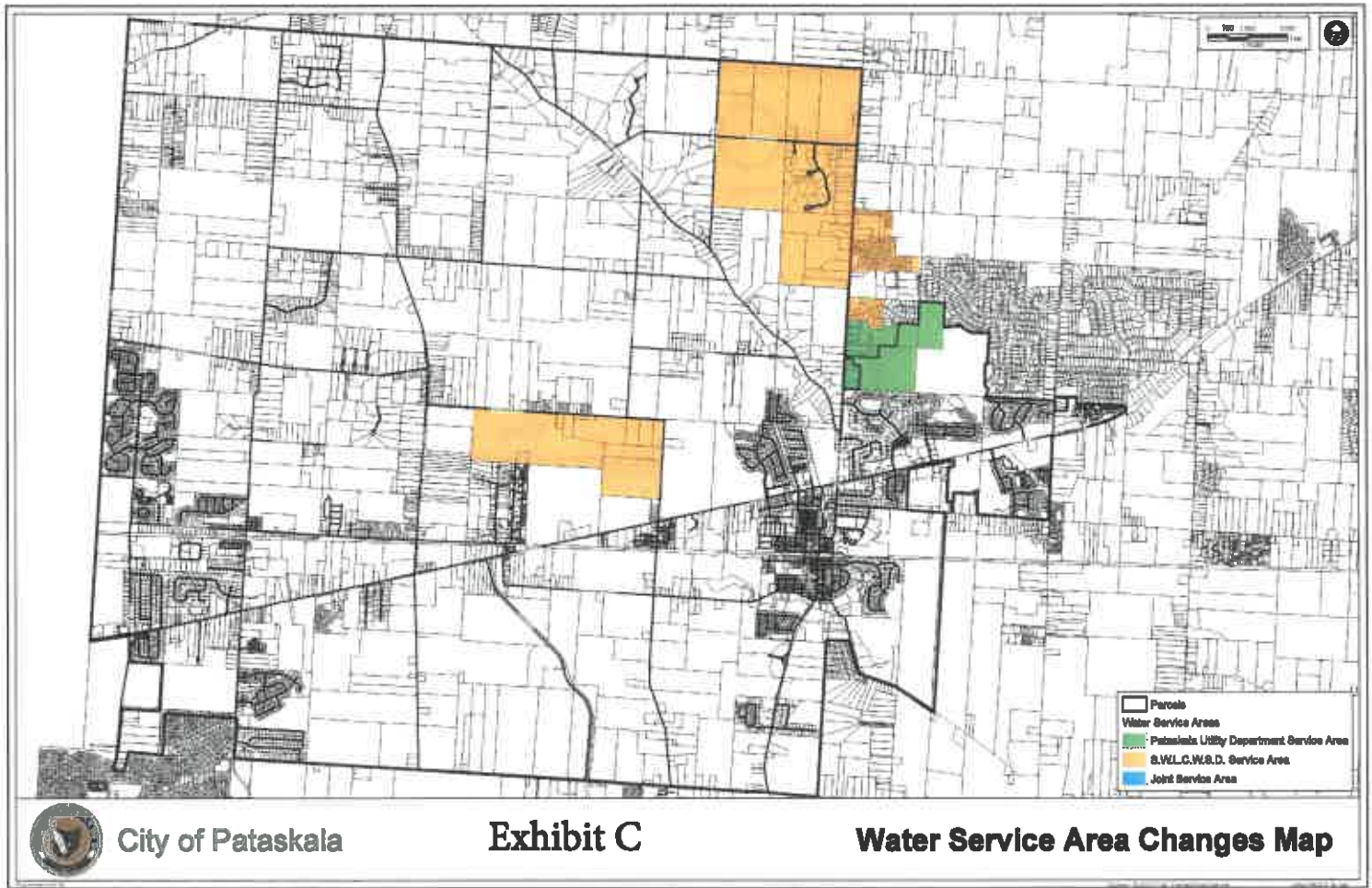

EXHIBIT B

**Concept Schematic for Interconnect Between
the City of Pataskala and the District**



City of Pataskala

Exhibit C

Water Service Area Changes Map

Exhibit C

Water Service Area Changes

Parcel number list

Fanin and Deagle Properties:

025-069066-00.001, 025-069066-00.004, 025-069066-00.000, 025-069066-00.002,
025-069078-00.000, 025-067746-02.000, 025-067746-01.000, 025-079170-00.000,
025-070356-00.000, 255-067746-00.000, 255-069066-00.005, 255-069072-00.000

Columbia Road Properties:

063-140586-00.000, 063-140598-00.001, 063-140598-01.000, 063-141774-00.000,
063-143034-00.000, 063-143034-00.001, 063-140586-00.001, 063-141264-00.000,
063-140874-00.002, 063-140874-00.001, 063-140874-00.000, 063-140772-00.000,
063-141444-00.000, 063-143136-00.000, 063-143142-00.000, 063-150072-00.000,
063-146136-00.000, 063-146142-00.000, 063-150246-00.000, 063-144720-00.000,
063-147030-00.000, 063-150390-00.000, 063-150804-00.000, 063-150054-00.000,
063-142020-00.000

Scotland Ridge Properties:

025-068514-00.004, 025-068514-00.005, 025-068514-00.006, 025-068514-00.045,
025-068514-00.007, 025-068514-00.008, 025-068514-00.009, 025-068514-00.010,
025-068514-00.011, 025-068514-00.012, 025-068514-00.013, 025-068514-00.047,
025-068514-00.014, 025-068514-00.015, 025-068514-00.016, 025-068514-00.017,
025-068514-00.018, 025-068514-00.019, 025-068514-00.020, 025-068514-00.049,
025-068514-00.031, 025-068514-00.032, 025-068514-00.033, 025-068514-00.034,
025-068514-00.035, 025-068514-00.046

Highland Estates and State Route 310 Properties:

025-068676-41.000, 025-068676-48.000, 025-068676-49.000, 025-068676-29.000,
025-068676-30.000, 025-068676-30.001, 025-068676-31.000, 025-068676-32.000,
025-068676-33.000, 025-068676-34.000, 025-068676-35.000, 025-068676-36.000,
025-076230-00.000, 025-068676-40.000, 025-068676-39.000, 025-068676-38.000,
025-068676-37.000, 025-076752-00.000, 025-068772-00.048, 025-068772-00.047,
025-068772-00.046, 025-068772-00.045, 025-068772-00.044, 025-068772-00.002,

025-068772-00.043, 025-068772-00.042, 025-068772-00.041, 025-068772-00.040,
025-068772-00.039, 025-068772-00.038, 025-068772-00.037, 025-068772-00.061,
025-068772-00.003, 025-068772-00.060, 025-068772-00.059, 025-068772-00.058,
025-068772-00.057, 025-068772-00.056, 025-068772-00.055, 025-068772-00.109,
025-068772-00.108, 025-068772-00.107, 025-068772-00.106, 025-068772-00.105,
025-068772-00.104, 025-068772-00.103, 025-068772-00.102, 025-068772-00.101,
025-068772-00.100, 025-068772-00.099, 025-068772-00.098, 025-068772-00.097,
025-068772-00.096, 025-068772-00.095, 025-068772-00.094, 025-068772-00.093,
025-068772-00.092, 025-068772-00.091, 025-068772-00.000, 025-068772-00.090,
025-068772-00.089, 025-068772-00.088, 025-068772-00.087, 025-068772-00.086,
025-068772-00.085, 025-068772-00.084, 025-068772-00.054, 025-068772-00.053,
025-068772-00.052, 025-068772-00.051, 025-068772-00.050, 025-068772-00.049,
025-068772-00.004, 025-068772-00.021, 025-068772-00.020, 025-068772-00.019,
025-068772-00.018, 025-068772-00.017, 025-068772-00.016, 025-068772-00.015,
025-068772-00.014, 025-068772-00.013, 025-068772-00.012, 025-068772-00.011,
025-068772-00.010, 025-068772-00.009, 025-068772-00.008, 025-068772-00.007,
025-068772-00.006, 025-068772-00.005, 025-068772-00.001, 025-068514-00.002,
025-068514-00.000, 025-068514-00.003, 063-141864-00.001, 063-141864-00.000,
063-141858-00.000, 064-152982-00.000, 064-152982-01.000, 064-152730-01.000,
064-152730-00.000, 064-152730-00.001, 063-141936-00.000, 064-152976-00.026,
064-152976-00.025, 064-152976-00.024, 064-152976-00.023, 064-152976-00.029,
064-152976-00.000, 064-152976-00.002, 064-152976-00.022, 064-152976-00.021,
064-152976-00.020, 064-152976-00.019, 064-152976-00.018, 064-152976-00.017,
064-152976-00.016, 064-152976-00.015, 064-152976-00.014, 064-152976-00.013,
064-152976-00.012, 064-152976-00.011, 064-152976-00.010, 064-152976-00.009,
064-152976-00.008, 064-152976-00.007, 064-152976-00.006, 064-152976-00.004,
064-152976-00.003, 064-152976-00.001, 064-152976-00.027, 064-152967-00.028,
064-152967-00.005, 064-153450-00.000, 064-153330-00.000, 064-153318-00.000,
064-152700-00.001, 064-152700-01.000, 064-152700-00.000, 064-152694-01.000,
064-152964-02.000, 064-152694-00.000, 064-152682-00.000, 064-152682-00.001,
064-142848-00.002, 064-142848-00.001, 064-142848-00.000, 064-152946-00.000,
064-152946-01.001, 064-152946-01.000, 064-152946-00.001, 064-152796-02.000,
064-152802-00.000, 064-152796-00.000, 064-152796-00.001

Exhibit B

AMENDED SANITARY SEWER SERVICE CONTRACT
BETWEEN
THE CITY OF PATASKALA, OHIO
AND
SOUTHWEST LICKING COMMUNITY
WATER AND SEWER DISTRICT

THIS AMENDED CONTRACT, made and entered on the date last executed below, by and between the City of Pataskala, an Ohio municipal corporation (the "City"), pursuant to the authority granted under Resolution No. 2019-059 by the Council for the City of Pataskala, and Southwest Licking Community Water and Sewer District (the "District"), a political subdivision established pursuant to R.C. Chapter 6119, pursuant to Resolution No. _____ by the District Board of Trustees. City and District are individually referred to as "Party" and collectively referred to as the "Parties."

WITNESSETH:

WHEREAS, the City and District previously entered into a Sanitary Sewer Service Contract on or about September 1, 2004 (the "Original Contract"); and

WHEREAS, the City and District now desire to enter into an amendment to such contract (the "Amended Contract"), providing for Sanitary Sewer Services within the corporate limits of the City and areas within the District, which overlap such corporate limits; as well as setting forth their respective obligations regarding Service Areas and Operational Support Connections.

NOW, THEREFORE, in consideration of the foregoing, and the mutual covenants and agreements set forth herein, the City and District agree as follows:

1. **Definition of "Project"**. The term "Project" as used hereinafter shall have the same definition as the term "water resource project" defined in R.C. 6119.011(G).

2. **Designation of Service Areas.** The City and District agree that the Service Areas described herein on Exhibit A, attached hereto and incorporated herein by reference, designates the Service Area of each Party.
3. **Provision of Services.** Except as provided herein, the Parties agree that only the Party in whose Service Area a property is located will be permitted to provide service to that property, except those properties already receiving service from either Party on the date of the execution of this Amended Contract.
4. **Bases for Designated Service Areas.**
 - A. The Parties specifically acknowledge and agree the Service Areas delineated herein are based upon sound engineering principles, existing infrastructure, tributary areas, system capabilities, future development patterns, as well as the ability to provide service.
 - B. The Parties further agree the Service Areas designated in Exhibit A have been developed utilizing sound engineering practices and principles, and therefore meet the requirements of the "feasible and economical" language contained in the merger document approved by the City and Lima Township voters at the time a vote on the merger of the two entities occurred. Potential shared service areas constitute predominantly future commercial and/or industrial developments where service by the Parties could potentially be more "feasible and economical" than either one or other Party attempting to service it alone, depending upon the capabilities necessary for these future developments.
5. **Denial of Service.** The Parties agree that either Party may deny service, on a case by case basis, to a potential user in its own Service Area for any reason, then offer the right to the

other Party to provide such services, provided that the denying Party has supplied such denial and subsequent offered assignment in written form. The receiving Party must provide to the offering Party a decision in written form on their desire to accept or deny the opportunity to service the denied area within 60 days of the offering Party's written denial of service. Once this assignment is effective, Exhibit A will be amended to show an accurate depiction of the service area.

6. **Inquiry Regarding Service.** If an inquiry regarding service is received by the Party in whose area the property requesting service is not located, that Party shall promptly refer the inquiries to the other Party.
7. **Fanin and Deagle Properties.** Notwithstanding anything in the Amended Contract to the contrary, the rights to provide sanitary service to the Fanin and Deagle Properties, identified in Exhibit B, will belong to the City at the effective date of this Amended Contract.
8. **Columbia Road Properties.** Notwithstanding anything in the Amended Contract to the contrary, the rights to provide sanitary service to the Columbia Road Properties, identified in Exhibit B, will belong to the District at the effective date of this Amended Contract.
9. **Highland Estates and State Route 310 Properties.** Notwithstanding anything to the contrary in this Amended Contract, once the District has installed a water service line at or near the boundary of Scotland Ridge Phase 2 and can begin providing water service, the rights to provide sanitary sewer service to the Highland Estates and State Route 310 Properties not currently serviced by the District, identified in Exhibit B, shall belong to the District.
10. **Termination/Resolution of Disputes.**

A. If either Party is unable to obtain the necessary permits and approvals for any construction activity required by this Amended Contract, or the Parties cannot complete such construction activity due to shortage of labor or materials, strikes, war, riot, weather conditions, governmental rules, regulations or orders, including orders, judgments of any court, arbitration panel, tribunal, or administrative agency, acts of God, or conditions beyond the control of either Party, the Party which cannot perform shall notify the other Party immediately upon learning it cannot perform according to the terms of this Amended Contract. The Party receiving notice shall then be entitled at its own discretion to terminate this Amended Contract or attempt to renegotiate the terms of the Amended Contract.

B. If a dispute arises under this Amended Contract, the Parties shall first attempt to resolve the dispute through mediation. Each Party shall bear its own cost/expense of mediation, including its proportionate share of the compensation and administrative expenses required by the mediator. The mediator shall be selected by the agreement of the Parties. If after 30 days, the Parties cannot agree on a mediator, the Party who is requesting mediation shall choose the mediator. If the dispute is not resolved in mediation, a Party may commence a lawsuit seeking specific performance of this Amended Contract, civil damages, costs, expenses, and any other relief and/or remedy available in law and/or equity.

11. **Term of Agreement/Renewal.** This Amended Contract is effective on the date last executed below and will continue for a twenty five (25) year term, subject to an automatic renewal for an additional twenty five (25) years, unless written notice is given by one Party to the other, on or before two (2) years prior to the end of the initial twenty five (25) year

term.

12. **Review of Amended Contract.** This Amended Contract shall be reviewed by the Parties jointly as often as the Parties deem necessary, during the term of the Amended Contract and any renewal term for the sole purpose of reviewing, revising, amending, or modifying current and future service areas in addition to review and confirmation of the District's infrastructure improvements within the corporate limits of the City. Both Parties recommend a joint review of this Amended Contract be conducted every five (5) years for the same stated purpose.

13. **Notices.** All notices, requests, and other communications ("Notice") to be given under this Amended Contract shall be in written form and shall be deemed to have been given, served, or made if transmitted by: certified mail, return receipt requested; common overnight carrier with delivery confirmation; facsimile with delivery conformation; or via email with delivery confirmation to the party to be notified as follows:
 - If to City: Pataskala Utilities Director
 - With copy to: City Administrator and Law Director
 - If to District: District General Manager
 - With copy to: District Board and District Attorney

14. **Entire Amended Contract/Modification.** This Amended Contract contains the entire agreement of the Parties with respect to this subject matter, and no amendment, modification, or waiver of any provision shall be valid unless in writing and signed by the Parties. The Parties may agree, in writing, to terminate this Amended Contract. This Amended Contract supersedes all prior discussions, agreements and undertakings of any kind between the Parties with respect to the subject matter of this Amended Contract, or

any particular contained therein.

15. **Assignment.** This Amended Contract is not assignable or transferable without the express written consent of the Parties.
16. **Binding Effect.** This Amended Contract shall be binding on, and insure to the benefit of, the Parties and their heirs, personal representatives, successors, and assigns, except as otherwise provided in this Amended Contract.
17. **Governing Law.** This Amended Contract and the legal relations between the Parties shall be governed by and construed in accordance with the laws of the State of Ohio.
18. **Waiver.** The waiver by any Party to this Amended Contract of a breach of any provision of this Amended Contract shall not be deemed a continuing waiver or a waiver of any subsequent breach of that or any other duty provision of this Amended Contract.
19. **Counterparts.** This Amended Contract may be executed by facsimile or email and in multiple counterparts by the Parties, and the counterparts shall collectively constitute a single, original, document, notwithstanding the fact that the signatures may not appear on the same page.
20. **Invalidity.** Should any provision of this Amended Contract be declared or determined to be null, void, inoperative, illegal, or invalid for any reason, the validity of the remaining parts, terms, or provisions shall not be affected thereby and they shall retain their full force and effect, and said null, void, inoperative, illegal or invalid part, term, or provision shall be deemed not to be a part of this Amended Contract.

IN WITNESS WHEREOF, the Parties have caused this Agreement to be executed by their
duly authorized officers on the dates appearing below.

CITY OF PATASKALA

**SOUTHWEST LICKING COMMUNITY
WATER AND SEWER DISTRICT**

By: _____
Its: _____

By: _____
Its: _____

Date: _____

Date: _____

APPROVED AS TO FORM:

APPROVED AS TO FORM:

Brian M, Zets, Law Director

John B. Albers, District Attorney

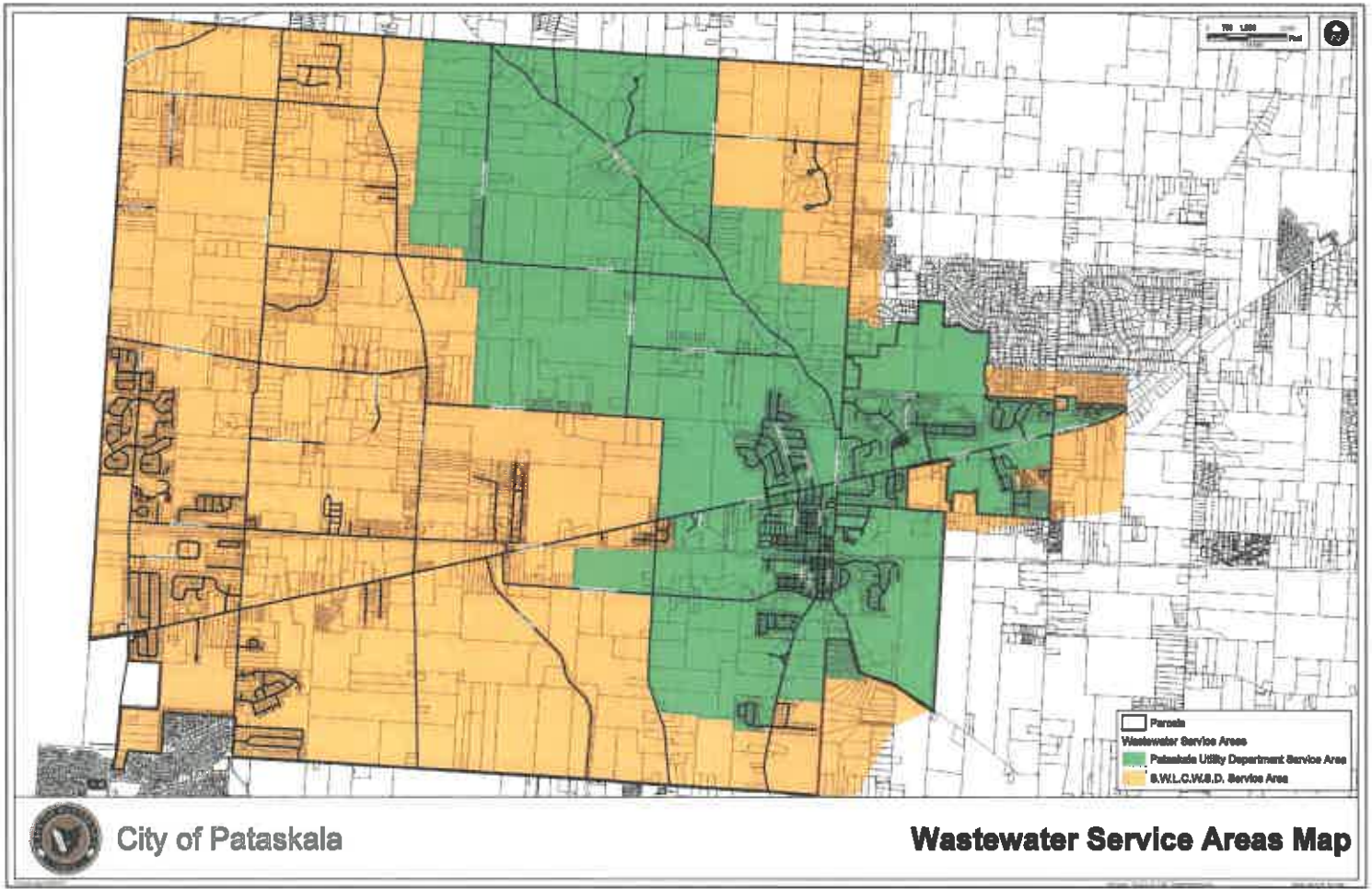

City of Pataskala

Wastewater Service Areas Map

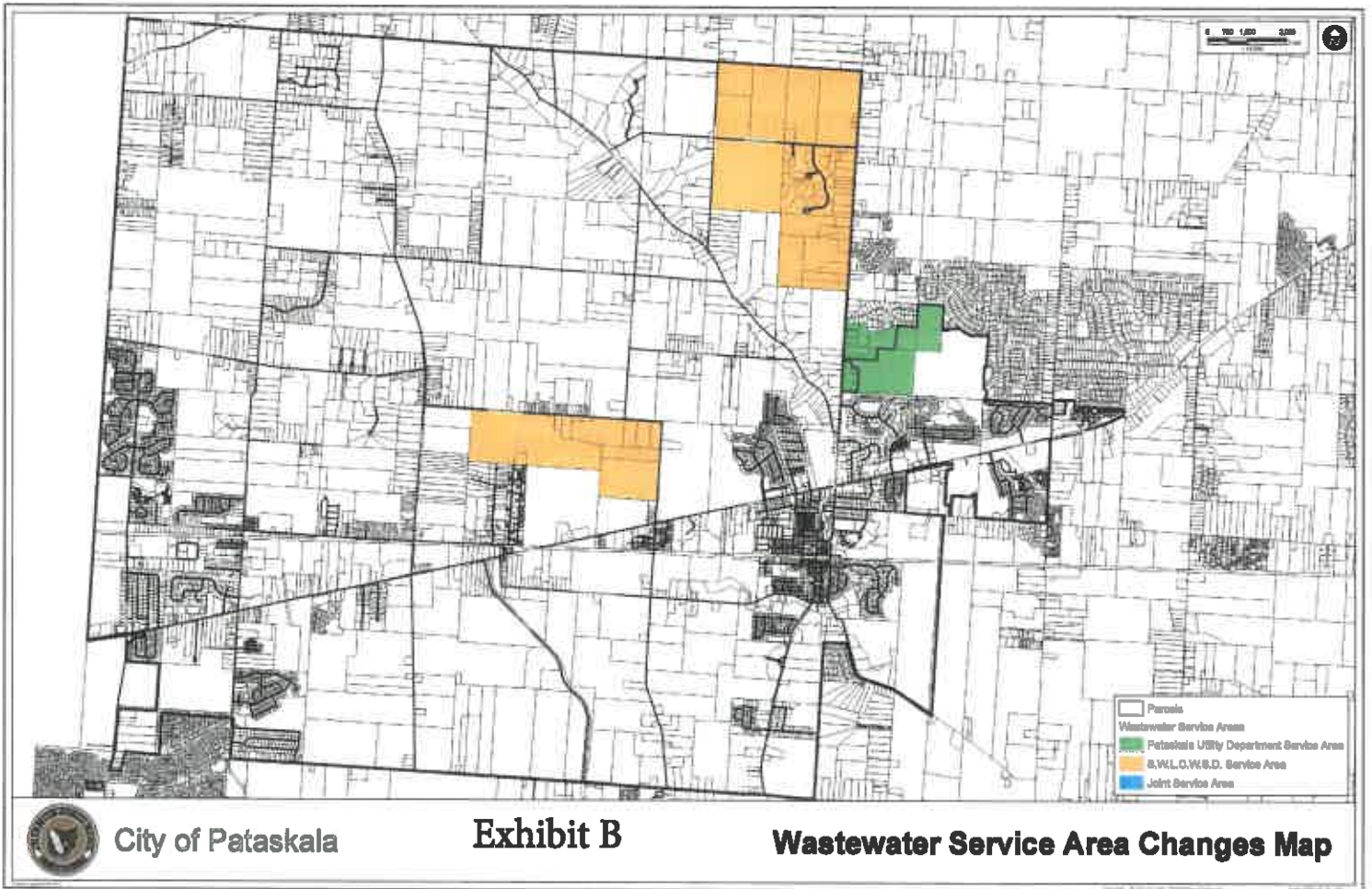

Exhibit B

Sewer Service Area Changes

Parcel number list

Fanin and Deagle Properties:

025-069066-00.001, 025-069066-00.004, 025-069066-00.000, 025-069066-00.002,
025-069078-00.000, 025-067746-02.000, 025-067746-01.000, 025-079170-00.000,
025-070356-00.000, 255-067746-00.000, 255-069066-00.005, 255-069072-00.000

Columbia Road Properties:

063-140586-00.000, 063-140598-00.001, 063-140598-01.000, 063-141774-00.000,
063-143034-00.000, 063-143034-00.001, 063-140586-00.001, 063-141264-00.000,
063-140874-00.002, 063-140874-00.001, 063-140874-00.000, 063-140772-00.000,
063-141444-00.000, 063-143136-00.000, 063-143142-00.000, 063-150072-00.000,
063-146136-00.000, 063-146142-00.000, 063-150246-00.000, 063-144720-00.000,
063-147030-00.000, 063-150390-00.000, 063-150804-00.000, 063-150054-00.000,
063-142020-00.000

Highland Estates and State Route 310 Properties:

063-141864-00.001, 063-141864-00.000, 063-141858-00.000, 064-152982-00.000,
064-152982-01.000, 064-152730-01.000, 064-152730-00.000, 064-152730-00.001,
063-141936-00.000, 064-152976-00.026, 064-152976-00.025, 064-152976-00.024,
064-152976-00.023, 064-152976-00.029, 064-152976-00.000, 064-152976-00.002,
064-152976-00.022, 064-152976-00.021, 064-152976-00.020, 064-152976-00.019,
064-152976-00.018, 064-152976-00.017, 064-152976-00.016, 064-152976-00.015,
064-152976-00.014, 064-152976-00.013, 064-152976-00.012, 064-152976-00.011,
064-152976-00.010, 064-152976-00.009, 064-152976-00.008, 064-152976-00.007,
064-152976-00.006, 064-152976-00.004, 064-152976-00.003, 064-152976-00.001,
064-152976-00.027, 064-152967-00.028, 064-152967-00.005, 064-153450-00.000,
064-153330-00.000, 064-153318-00.000, 064-152700-00.001, 064-152700-01.000,
064-152700-00.000, 064-152694-01.000, 064-152964-02.000, 064-152694-00.000,
064-152682-00.000, 064-152682-00.001, 064-142848-00.002, 064-142848-00.001,
064-142848-00.000, 064-152946-00.000, 064-152946-01.001, 064-152946-01.000,

064-152946-00.001, 064-152796-02.000, 064-152802-00.000, 064-152796-00.000,
064-152796-00.001

