



**City of Pataskala Planning & Zoning Department**  
**Scott Fulton, Director of Planning**  
*Director of Planning's Report to Council*

---

**Current Projects**

➤ **Planning and Zoning Commission**

**May 1, 2024 Hearing:** No applications were submitted for the May 1, 2024 Planning and Zoning Commission hearing; therefore, the hearing has been canceled.

➤ **Board of Zoning Appeals**

**May 14, 2024 Hearing:** The following applications are scheduled to be heard at the May 14, 2024 Board of Zoning Appeals hearing:

- Application CU-24-003: Resolute Industrial, LLC. dba Mobile Air and Power Rentals is Requesting approval of a Conditional Use pursuant to section 1215.08 of the Pataskala Code to allow for outdoor storage on the property located at 87 Cypress Street.
- Application VA-24-003: Charles W. Robbins is requesting approval of four (4) Variances from the Pataskala Code in order to allow for an Electronic Message Center sign that will exceed the maximum allowable sign area, sign height, changeable copy sign area, and for a changeable copy sign to not be fully framed for the property located at 12477 Broad Street.
- Application VA-24-003: Todd Ward is requesting a total of three (3) Variances. The first from Section 1253.05(C)(1)(a)(3) to allow for the proposed mounding to be outside the parking setback on Etna Parkway. Second, from Section 1253.05(C)(1)(b)(3) to allow the proposed mounding to be outside the parking setback on Refugee Road, and lastly from Section 1253.05(C)(1)(a)(3) to allow for gap(s) in the mounding along Etna Parkway for the property located at 3000-3007 Etna Parkway.

➤ **Ordinance 2023-4458**

- Fair Lady Development Holdings, LLC is requesting to rezone +/- 192.666-acres from the RR – Rural Residential and R-87 – Medium-Low Density Residential districts to the PM – Planned Manufacturing district pursuant to Section 1217.13 of the Pataskala Code for properties located at 0 Clark State Road, 0 Summit Road and 14530 Graham Road (PID: 063-140550-00.000, 063-141840-00.000, 063-151764-00.000, and 063-145944-00.001).
- The Planning and Zoning Commission recommended disapproval of the application on October 4, 2023.
- A Council public hearing was scheduled for December 4, 2023 at 6:00pm, but has been postponed until January 16, 2024 at 6:00pm

- Staff were requested to prepare a list of the Planning and Zoning Commission's concerns regarding the Fair Lady rezoning and staff's assessment of how the updated PM – Planned Manufacturing regulations would, or would not, address these concerns.
- The first reading of the ordinance was on January 22, 2024 and was subsequently tabled.
- Staff received a copy of proposed easement language designed to address concerns and is in the process of reviewing and commenting on the language.
- Staff reviewed the proposed easement language and provided comments to the applicant on February 22. Staff is awaiting a revised copy of the proposed easement language.
- On March 8, 2024 revised easement language was submitted based upon staff's comments; however, the property owner left a voicemail on March 7, 2024 indicating that she wanted the City to cease all activity related to the project. She stated that she has other plans for the property.
- On March 13, 2024, the issue stemming from March 7, 2024 was resolved and the ordinance remained on the agenda.
- On March 20, 2024 staff provided additional comments on the revised easement language.
- On April 5, 2024 a development agreement, revised easement language, and a revised landscaping plan were submitted for comment (attached).
- On April 10, 2024 staff provided comments to the applicant on the April 5, 2024 submittal (attached).
- On April 17, 2024 staff provided dates and times to the applicant, as requested, to set up a meeting to discuss my comments; however, no meeting was held.
- Staff is happy to answer any questions related to this rezoning ordinance.

➤ **Red Rock Planned Manufacturing Application**

- Red Rock received a recommendation of conditional approval of their Planned Manufacturing application (PM-24-001) at the April 3, 2024 Planning and Zoning Commission hearing. Per the updated Planned Manufacturing regulations, the application proceeds to Council for final approval.
- Two conditions were placed on the application requiring variances to be obtained from the Board of Zoning Appeals.
- Pursuant to City policy, the Planned Manufacturing application cannot proceed to Council for consideration until after the Board of Zoning Appeals hearing on May 14, 2024. This will also delay the third and final reading of the CRA ordinances until approvals from both the Planning and Zoning Commission and the Board of Zoning Appeals have been obtained.

➤ **Ordinance 2024-4464**

- Ryan Badger, Badger Land Concepts, is requesting to rezone five (5) lots, totaling 1.242 +/- acres, from R-20 – Medium Density Residential to GB – General Business pursuant to Section 1217.13 of the Pataskala Code for the properties located at 8855 East Broad Street and 18 South Belmar Drive.
- The Planning and Zoning Commission recommended approval of the application on March 6, 2024.

- A Council public hearing is scheduled for May 20, 2024 at 6:30pm.

➤ **Ordinance 2024-4465**

- Ryan Badger, Badger Land Concepts, is requesting to rezone 0.41 +/- acres from R-20 – Medium Density Residential to GB – General Business pursuant to Section 1217.13 of the Pataskala Code for the property located at 43 South Belmar Drive.
- The Planning and Zoning Commission recommended approval of the application on March 6, 2024.
- A Council public hearing is scheduled for May 20, 2024 at 6:45pm.

➤ **Ordinance 2024-4466**

- Connie K. Klema is Requesting a recommendation of approval to rezone three (3) properties, totaling 136.75 +/- acres, from AG – Agricultural to PM – Planned Manufacturing with a Planned District Overlay pursuant to Sections 1217.13 and 1261.06 of the Pataskala Code for the properties located at 7482 Columbia Road and 0 Columbia Road.
- The Planning and Zoning Commission recommended approval of the application on March 6, 2024.
- A Council public hearing is scheduled for May 6, 2024 at 6:15pm.

➤ **Ordinance 2024-4467**

- The City of Pataskala is requesting to amend Chapter 1257 – Flood Damage Prevention and Flood Plain Overlay District (FP) pursuant to Section 1217.10 of the Pataskala Code.
- The Planning and Zoning Commission recommended approval of the application on April 3, 2024.
- A Council public hearing is scheduled for May 6, 2024 at 6:45pm.

➤ **100 Connor Avenue**

- The Planning and Zoning Department has been working on an ongoing code violation of Section 1223.05(a)(2) for litter, refuse and debris since October of 2022.
- As this has not achieved compliance, the Planning and Zoning Department may refile the case as a violation of Chapter 723 – Junk Yards, identifying the property as an illegal junk yard and giving the City the authority to clean up the property, if so desired.
- The Planning and Zoning Department will keep Council apprised of this case as more information is known.

➤ **Pataskala CRA's**

- The Planning and Zoning Department has compiled information on the existing CRA's within the City for assessment and provided them to the Montrose Group.
- This assessment will determine the efficiency of existing CRA areas and determine if they should be expanded, retracted, or otherwise adjusted.

- Staff has completed the CRA Process Guide so that all parties (Council, Administration and the Company) are on the same page and know what to expect when navigating the CRA process. It is designed to be policy, rather than legislation, so that it can remain flexible.
- Staff and Montrose are working on the creation of a CRA for the northwest “innovation” district as outlined in the Comprehensive Plan.
- Staff presented a summary of the proposed Northwest Innovation District CRA to the Development Committee on June 21, 2022 for consideration. The Development Committee recommended that staff proceed with the formal creation of the CRA.
- A draft ordinance is currently under review by the Law Director. Once completed it, and associated CRA creation documents, will be presented to Development Committee.

➤ **Comprehensive Plan**

- The Planning and Zoning Department has identified the Economic Development goals outlined in the Comprehensive Plan for implementation and has reviewed them with Montrose and the City Administrator.
- The Planning and Zoning Department is prioritizing the planning and zoning goals outlined in the Comprehensive Plan for implementation. It is likely that Conservation Rural/Suburban regulations will be the first item addressed.
- With the passage and implementation of Impact Fees, staff has completed Action 6.3.1 of the Comprehensive Plan which states: “Consider the use of impact fees as a tool plan for and cover the cost associated with future development”.
- Montrose is working on the creation of a CRA for the northern “innovation” district as outlined in the Comprehensive Plan as Action 4.2.2 which states: “Continue to market and explore opportunities for the northern innovation district”.
- Staff is working on the creation of the Summit Road TIF as outlined in the Comprehensive Plan as Action 2.2.2 which states: “Establish the area as a primary showplace for the City through public and private improvements”.
- Staff was asked to prepare a progress list for the goals and objectives contained in the Comprehensive Plan.

## **Fair Lady Comments – April 10, 2024**

### Easement – Section 4 - Landscaping

1. Appendix 1 does not reference “Option C” and there are two different requirements in the Planned Manufacturing regulations for “Option C” based upon building height. To avoid confusion, I would recommend removing the reference to “Option C”.

### Appendix 1

1. The screening/mounding does not extend around the entirety of the property.
  - a. The gap for the future roundabout and the stream is understandable.
  - b. The screening/mounding should extend along the entire northern portion of the property abutting Jersey Township as these properties contain both a residential use and district. Furthermore, there is no guarantee that Jersey Township would rezone these properties in the future for an industrial use. A gap for the access road is understandable.
  - c. Due to the wetlands, there are gaps on the east, south and west side of the property. Although the wetlands were identified on previous plans, it still showed screening/mounding in those areas. This led me to believe that those wetlands would be appropriately mitigated to allow the screening/mounding to continue.
2. The screening/mounding along Clark State Road adjacent to the wetland will exceed the maximum slope.

### Development Agreement

1. The font doesn't match on the fourth “Whereas”.
2. Zoning Considerations
  - a. The City's planning staff and administration do not agree to actively support the Zoning Application through the rezoning process. Even if this were left in, I don't believe it would be enforceable as the agreement would not take effect until after the rezoning is complete.
  - b. While I can understand the reasoning for its inclusion, I'm not comfortable allowing the property to be exempt from any future update to the zoning code.

## DEVELOPMENT AGREEMENT

This DEVELOPMENT AGREEMENT (this “Agreement”) is made and entered into as of the Effective Date as defined herein by and among the **CITY OF PATASKALA** an Ohio municipal corporation duly organized and validly existing under the Constitution and the laws of the State of Ohio and its Charter (the “**City**”), and **FAIR LADY DEVELOPMENT LLC**, a Ohio limited liability company (“**Developer**”). The City and Developer may be referred to hereinafter individually as a “**Party**” and collectively as the “**Parties**”.

WHEREAS, Developer is or will be owner of certain real property located south of Morse Road and east of Beech Road SW in Licking County, Ohio, being Licking County Parcel Nos. 063-141840-00.000; 063-140550-00.000; 063-145944-00.001 and 063-151764-00.000 containing 192.6+/- acres as more fully described on Exhibit A attached hereto (the “**Property**”); and

WHEREAS, Developer intends to subdivide the Property to allow for separate building sites as part of an industrial park, each building site being a “**Parcel**”; and

WHEREAS, Developer intends to develop all Parcels together as a single industrial park development such that all Parcels will share certain entranceways, roadways, storm water drainage facilities, water lines and sanitary sewer lines, common areas, landscaping and lighting;

WHEREAS, Developer presently has a pending rezoning application to rezone the Property to the Property to the Planned Manufacturing (PM) zoning by the City of Pataskala is final beyond any applicable appeal or referendum periods (the “**Zoning Application**”) that is now before Pataskala City Council for consideration; and

WHEREAS, the City and Developer desire to set forth their mutual understandings and agreements with respect to development matters that may affect the property should said Zoning Application be approved by and through their execution of this Agreement; and

NOW THEREFORE in consideration of the promises and covenants contained herein, the Parties agree to the foregoing and as follows:

1. **Zoning Considerations.** Developer’s intended use of the Property is that of an industrial park under the Planned Manufacturing (PM) zoning district. Developer has submitted the Zoning Application consistent with such intended use. The City’s planning staff and administration have reviewed the Zoning Application and agree to actively support the Zoning Application through the rezoning process. If the Zoning Application is approved by the Pataskala City Council past all applicable referendum or appeal periods, Developer will have the right to development the Property under the Applicable Rules as defined herein. No addition to, or modification of, the Applicable Rules including, without limitation, any zoning or building regulation, adopted effective after the Effective Date, shall be applied to the Property; provided, however, that any applicable State of Ohio building codes in effect at the time of any application for a building permit shall govern. “**Applicable Rules**” means all of the rules, regulations, ordinances, official policies of the City.

2. **Landscaping.** It is the City’s desire that all landscaping and mounding required by the ordinances of the City of Pataskala be installed on the Property prior to the issuance of a certificate

of compliance or occupancy permit for any building constructed anywhere on the Property regardless of how said Property is subdivided. To that end, the Developer shall install all landscaping and mounding along the property lines adjacent to the residential uses and along the public right of way as illustrated and described on Appendix 1 attached hereto prior to the issuance of a certificate of compliance or occupancy permit for any building constructed anywhere on the Property regardless of how it is subdivided.

Until such time as all or any part of the Property is sold to a third party, the Developer shall maintain the landscaping and mounding in a first class commercial condition at the Developer's sole expense. At such time as any part of the Property is sold to a third party, the Developer will record a master declaration of easements, covenants and restrictions setting for the provisions for the creation of an association of the industrial park owners for the purpose of coordinating maintenance and cost sharing of the landscaping and mounding, entranceways, lighting, shared storm water facilities and other common elements in the industrial park.

3. **Miscellaneous.**

a) **Assignment.** Except as expressly provided hereunder, this Agreement may not be assigned without the prior written consent of the non-assigning Parties. Notwithstanding the foregoing or any other provision of this Agreement:

(i) Developer shall be permitted to assign its rights and obligations under this Agreement to an affiliated business entity of the Developer; and

(ii) Developer shall be permitted to sell and convey all or a portion of the Property that is under its ownership to another person or entity, and the purchasing party shall be required to assume, in a written instrument executed by Developer and the purchasing party, the obligations of the Developer under this Agreement as they relate to the portion of the Property being conveyed to the purchasing party, and

(iii) entitled to the rights of the Developer under this Agreement as they relate to the portion of the Property that is conveyed to the purchasing party.

Developer shall deliver to the City written notice of any assignment of its rights and obligations under this Agreement and, when applicable, written evidence of a purchasing party's assumptions of the rights and obligations with respect to any portion of the Property being purchased by the purchasing party, both within a reasonable amount of time after such assignment or purchase is completed.

b) **Binding Effect.** The provisions of this Agreement shall be binding upon the successors and/or assigns of the Parties.

c) **Captions.** The captions and headings in this Agreement are for convenience only and in no way define, limit or describe the scope or intent of any provisions or sections of this Agreement.

d) **Governing Law.** This Agreement shall be governed by and construed in accordance with the laws of the State of Ohio without regard to its principles of conflicts of laws.

e) Severability. If any provision of this Agreement, or any covenant, obligation or agreement contained herein is determined by a court to be invalid or unenforceable, that determination shall not affect any other provision, covenant, obligation or agreement, each of which shall be construed and enforced as if the invalid or unenforceable portion were not contained herein. That invalidity or unenforceability shall not affect any valid and enforceable application thereof, and each such provision, covenant, obligation or agreement shall be deemed to be effective, operative, made, entered into or taken in the manner and to the full extent permitted by law.

f) Effective Date. The Effective Date of this Agreement shall be the date that the rezoning of the Property to the Planned Manufacturing (PM) zoning by the City of Pataskala is final beyond any applicable appeal or referendum periods.

g) Enforcement. The City shall have the right to enforce the terms of this Declaration. Any violation of this Declaration shall be treated as a violation of the City of Pataskala zoning ordinances pursuant to Chapter 1209 and therefore shall be subject to the jurisdiction of the Pataskala Mayor's Court.



**DECLARANT:**

**FAIR LADY LLC**

By: \_\_\_\_\_

Name: \_\_\_\_\_

Title: \_\_\_\_\_

STATE OF OHIO

COUNTY OF \_\_\_\_\_, SS:

The foregoing instrument was acknowledged before me this \_\_\_ day of \_\_\_\_\_, 202\_, by  
\_\_\_\_\_ (name), the \_\_\_\_\_ (title) of \_\_\_\_\_ LLC.

\_\_\_\_\_  
Notary Public

**CITY:**

**City of Pataskala, an Ohio municipality**

By: \_\_\_\_\_

Its: \_\_\_\_\_

STATE OF OHIO

COUNTY OF \_\_\_\_\_, SS:

The foregoing instrument was acknowledged before me this \_\_\_ day of \_\_\_\_\_, 202\_, by \_\_\_\_\_ (name), the \_\_\_\_\_ (title) on behalf of the City of Pataskala, Ohio.

\_\_\_\_\_  
Notary Public

## Declaration of Shared Access and Easements

This Declaration of Shared Access and Easements is hereby made this \_\_\_\_ day of \_\_\_\_\_, 2024, by Fair Lady LLC (hereinafter referred to as “Declarant”) and the City of Pataskala (hereinafter referred to as the “City”).

WHEREAS, the Declarant is owner of certain real property located south of Morse Road and east of Beech Road SW in Licking County, Ohio, being Licking County Parcel Nos. 063-141840-00.000; 063-140550-00.000; 063-145944-00.001 and 063-151764-00.000 containing 192.6+/- acres as more fully described on Exhibit A attached hereto (the “Property”); and

WHEREAS, the Declarant intends to subdivide the Property to allow for separate building sites as part of an industrial park, each building site being a “Parcel”; and

WHEREAS, the Declarant intends to develop all Parcels together as a single industrial park development such that all Parcels will share certain entranceways, roadways, storm water drainage facilities, water lines and sanitary sewer lines, common areas, landscaping and lighting;

WHEREAS, because there will be multiple Parcels within the industrial park development, the Declarant intends for this Declaration to set forth the shared easements, rights and obligations among the Parcels; and

WHEREAS, the City desires to ensure that the Property be developed and landscaped in accordance with Appendix 1 attached hereto and therefore is a party to this Declaration to ensure compliance with its zoning ordinances;

NOW THEREFORE, the Declarant sets forth the following declaration for shared access and easements:

**§1. Water and Sewer Service.** The Parcels will share certain water and sanitary service lines and other facilities, included a master water meter and master sewer meter (the “Shared Utility Service Facilities”). There are hereby created perpetual, non-exclusive easements upon, across and over the Parcels as necessary for all Shared Utility Service Facilities.

**§2. Storm Water Drainage.** The Parcels will share the use of certain storm water drainage facilities (the “Shared Storm Water Facilities”). There are hereby created perpetual, non-exclusive easements upon, across and over the Parcels as necessary for all Shared Storm Water Facilities. All Shared Storm Water Facilities shall be constructed prior to the issuance of a certificate of compliance or occupancy permit for any building constructed anywhere on the Property regardless of how it is subdivided.

**§3. Roadways.** There are hereby created perpetual, non-exclusive easements upon, across and over all entranceways, roadways, sidewalks, and paths now or hereafter located on the Parcels for ingress and egress to, from, between and over each of the

Parcels to access all contiguous public roadways as permitted and approved by the City of Pataskala and Licking County (the “Shared Roadways”). Such Shared Roadways easements shall be for the benefit of the Parcels, all current and future occupants of the Parcels and their respective lessees, agents, employees and invitees, and all police, fire protection, ambulance, mail delivery and similar personnel.

**§4. Landscaping.** There are hereby created perpetual, non-exclusive easements upon, across and over all of the Parcels to the allow for the installation, maintenance, repair and replacement of mounding and landscaping required under City of Pataskala zoning ordinances (“Shared Landscaping”). Such Shared Landscaping easements shall be for the benefit of the Parcels, all current and future occupants of the Parcels and their respective lessees, agents, employees and invitees, and the City of Pataskala. All Shared Landscaping, including but not limited to the Shared Landscaping required by City of Pataskala zoning ordinances to be installed along the property lines of the Property adjacent to residential uses and along the public right of way as illustrated as Option C on Appendix 1, shall be installed by the developer of all or part of the Property prior to the issuance of a certificate of compliance or occupancy permit for any building constructed anywhere on the Property regardless of how it is subdivided.

**§5. Effective Date of Restrictions.** The easements, covenants and restrictions set forth in this Declaration shall become effective on the date that the rezoning of the Property to the Planned Manufacturing (PM) zoning by the City of Pataskala is final beyond any applicable appeal or referendum periods.

**§6. Perpetual Restrictions.** The easements, covenants and restrictions set forth in this Declaration shall be perpetual, shall run with the land and shall be binding on all future owners of the Property, their successors and assigns. This Declaration as set forth herein shall not be amended, released, extinguished or otherwise modified without the prior written consent of the current owner(s) of the Parcels and the City of Pataskala.

**§7. Separability.** Each provision of this Declaration and the application thereof to the Property are hereby declared to be independent of and severable from the remainder of this Declaration. If any provision contained herein shall be held to be invalid or to be unenforceable or not to run with the land, such holding shall not affect the validity or enforceability of the remainder of this Declaration.

**§8. Enforcement.** **The City shall have the right to enforce the terms of this Declaration. Any violation of this Declaration shall be treated as a violation of the City of Pataskala zoning ordinances pursuant to Chapter 1209 and therefore shall be subject to the jurisdiction of the Pataskala Mayor’s Court.**

**§9. Governing Law.** This Declaration shall be governed by, and construed in accordance with the laws of the State of Ohio.

*(Signature Page to Follow)*

**DECLARANT:**

**FAIR LADY LLC**

By: \_\_\_\_\_  
Name: \_\_\_\_\_  
Title: \_\_\_\_\_

STATE OF OHIO  
COUNTY OF \_\_\_\_\_, SS:

The foregoing instrument was acknowledged before me this \_\_\_ day of \_\_\_\_\_,  
202\_, by \_\_\_\_\_ (name), the \_\_\_\_\_ (title) of  
\_\_\_\_\_ LLC.

\_\_\_\_\_  
Notary Public

**CITY:**

**City of Pataskala, an Ohio municipality**

By: \_\_\_\_\_  
Its: \_\_\_\_\_

STATE OF OHIO  
COUNTY OF \_\_\_\_\_, SS:

The foregoing instrument was acknowledged before me this \_\_\_ day of \_\_\_\_\_,  
202\_, by \_\_\_\_\_ (name), the \_\_\_\_\_ (title) on behalf of the  
City of Pataskala, Ohio.

\_\_\_\_\_  
Notary Public

Instrument prepared by:

Jill S. Tangeman, Esq.  
Vorys, Sater, Seymour and Pease LLP  
52 East Gay Street

Columbus, Ohio 43215

Exhibit A

The Property

Appendix 1

Shared Landscaping Between Industrial and Residential Uses



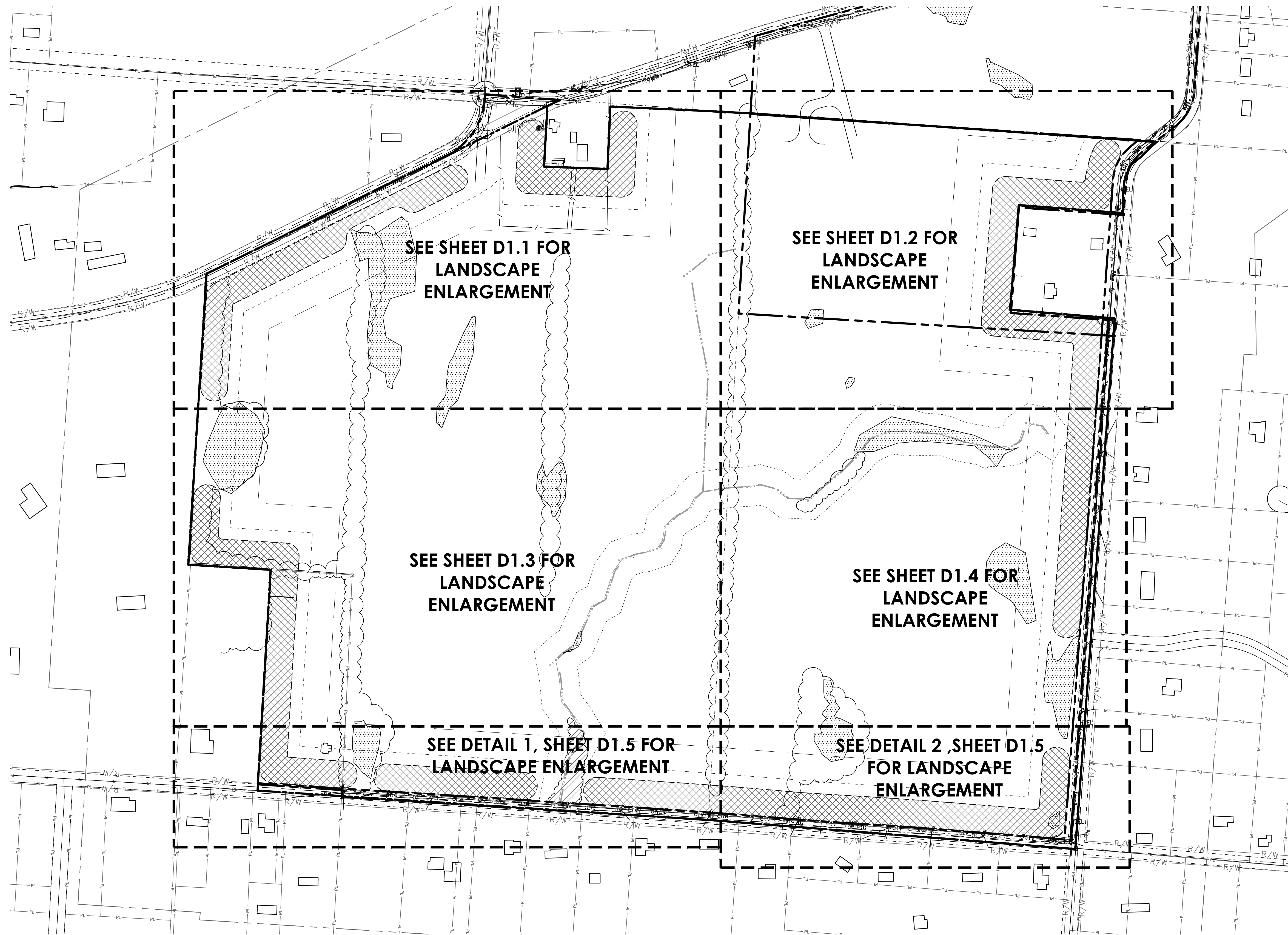

### MINIMUM LANDSCAPE REQUIREMENTS

MOUND LANDSCAPE	* MIXTURE OF DECIDUOUS, EVERGREEN TREES AND SHRUBS. * MINIMUM OPACITY OF 75% WITHIN 5 YEARS OF PLANTING TO A TOTAL HEIGHT OF AT LEAST 6' ABOVE THE TOP OF THE MOUND.
TREE INSTALLATION SIZE	* TREE SIZE SHALL BE A MIX OF AT LEAST THREE DIFFERENT SIZES RANGING FROM 2-3 CALIPER IN. * NO MORE THAN 50% SHALL BE 2-IN CALIPER.
TREE SPECIES DIVERSITY	* AT LEAST 5 SPECIES PER PROPERTY * ONE SPECIES CAN BE NO MORE THAN 40% OF THE OVERALL QUANTITY. * TREES SHALL BE NATIVE AND FROM REGIONAL NURSERY.
TREE SPACING	* RANDOMLY SPACED IN STAGGERED PATTERN * MINIMUM OF 30 TREES PER 100 LINEAR FEET
UNDERPLANTING	* TREES SHALL BE UNDERPLANTED WITH TURF GRASS AND/OR GROUNDCOVER TO FULLY COVER REMAINDER OF LANDSCAPE AREA.

### PLANT KEY TYPICALS

SEE PLANT LIST FOR SPECIFIC PLANT SPECIES

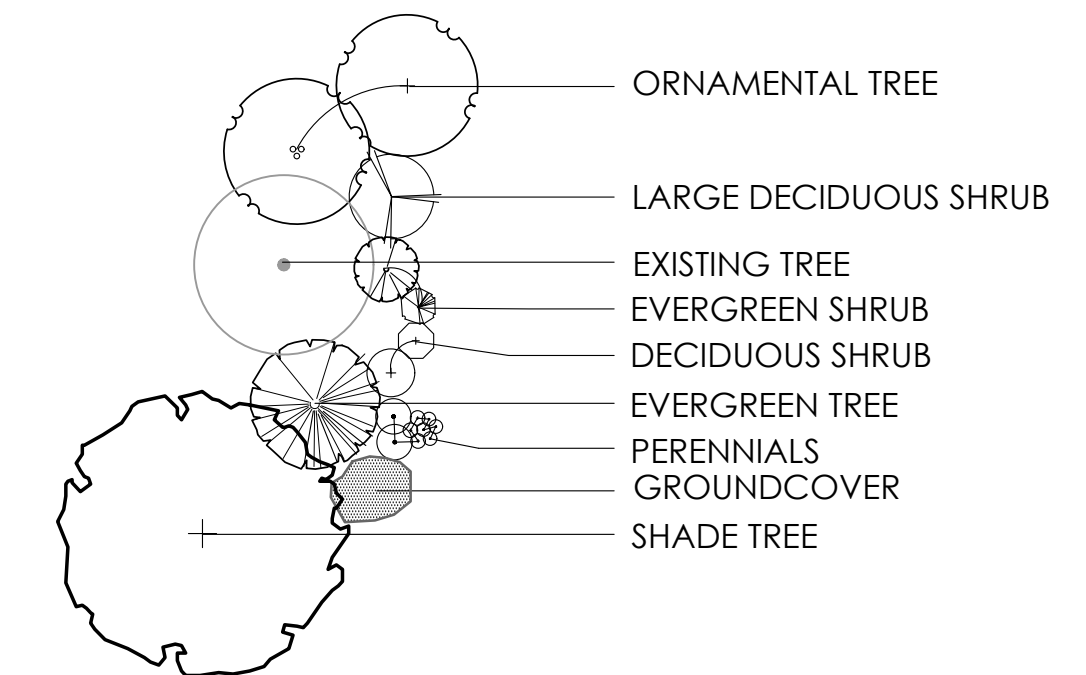

### SITE KEY

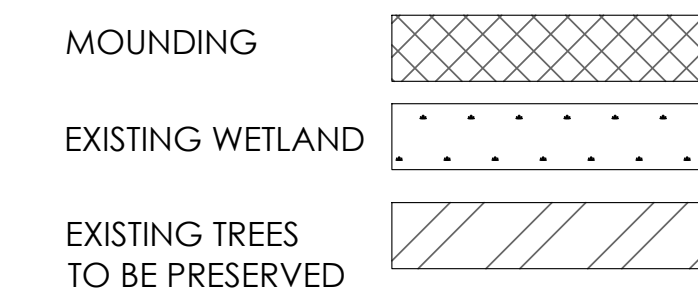

## LANDSCAPE BUFFER PLAN - OVERALL

## EXHIBIT D-1

# FAIR LADY TECHNOLOGY PARK

PREPARED FOR FAIR LADY DEVELOPMENT HOLDINGS LLC

DATE: 4.3.24

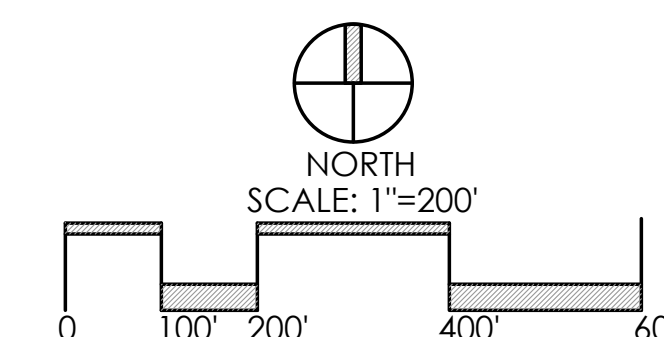

**Faris Planning & Design**

LAND PLANNING

LANDSCAPE ARCHITECTURE

4876 Cemetery  
p. [614] 487-1964

Hilliard, OH 43026  
www.farisplanninganddesign.com



# MINIMUM LANDSCAPE REQUIREMENTS

MOUND LANDSCAPE	* MIXTURE OF DECIDUOUS, EVERGREEN TREES AND SHRUBS. * MINIMUM OPACITY OF 75% WITHIN 5 YEARS OF PLANTING TO A TOTAL HEIGHT OF AT LEAST 6' ABOVE THE TOP OF THE MOUND.
TREE INSTALLATION SIZE	* TREE SIZE SHALL BE A MIX OF AT LEAST THREE DIFFERENT SIZES RANGING FROM 2-3 CALIPER IN. * NO MORE THAN 50% SHALL BE 2-IN CALIPER.
TREE SPECIES DIVERSITY	* AT LEAST 5 SPECIES PER PROPERTY * ONE SPECIES CAN BE NO MORE THAN 40% OF THE OVERALL QUANTITY. * TREES SHALL BE NATIVE AND FROM REGIONAL NURSERY.
TREE SPACING	* RANDOMLY SPACED IN STAGGERED PATTERN * MINIMUM OF 30 TREES PER 100 LINEAR FEET
UNDERPLANTING	* TREES SHALL BE UNDERPLANTED WITH TURF GRASS AND/OR GROUNDCOVER TO FULLY COVER REMAINDER OF LANDSCAPE AREA.

## PLANT KEY TYPICALS

SEE PLANT LIST FOR SPECIFIC PLANT SPECIES

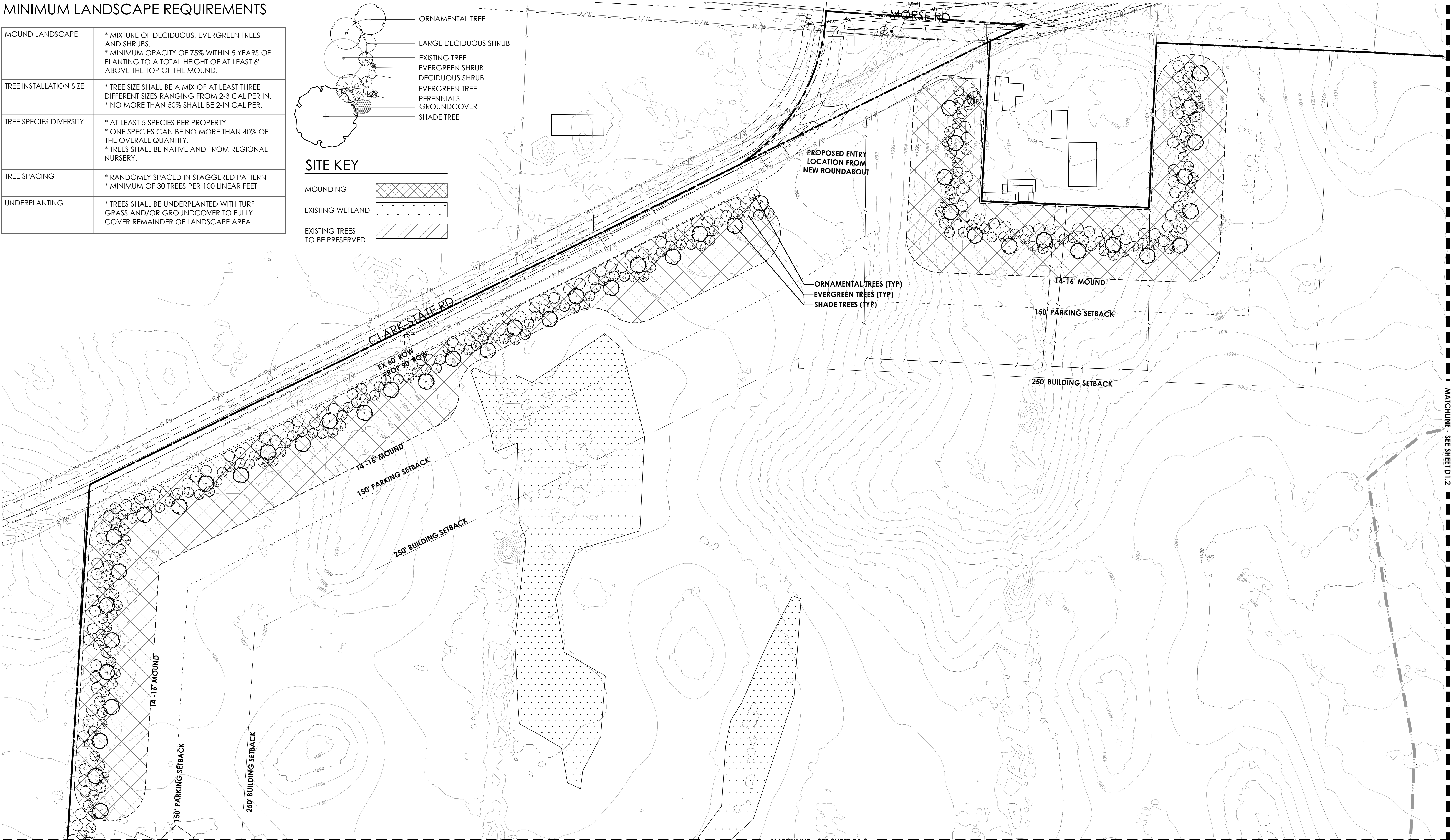
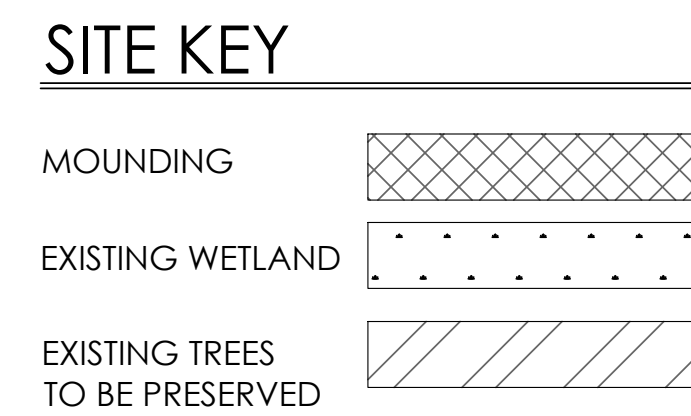
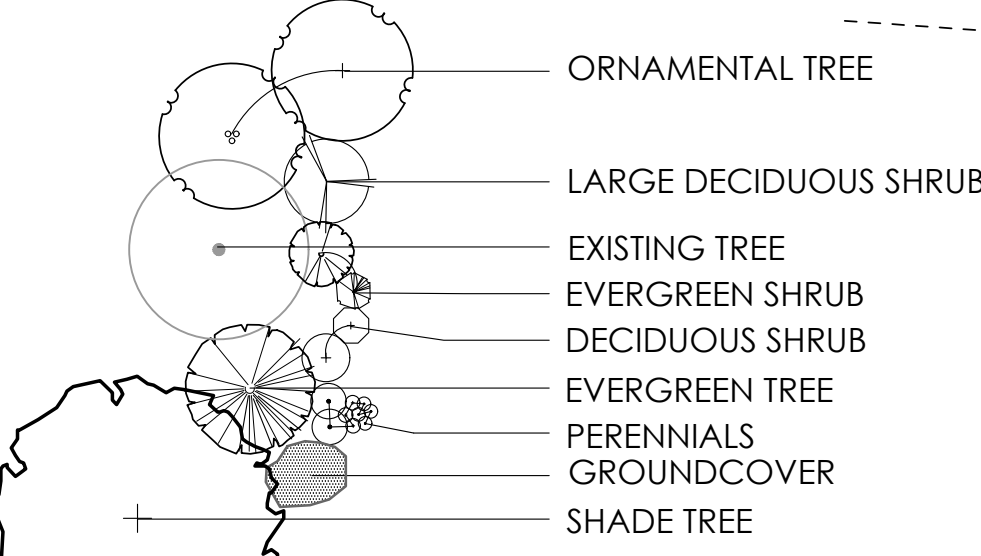

MATCHLINE - SEE SHEET D1.3

MATCHLINE - SEE SHEET D1.2

# LANDSCAPE BUFFER PLAN - A

# EXHIBIT D-1.1

# FAIR LADY TECHNOLOGY PARK

PREPARED FOR FAIR LADY DEVELOPMENT HOLDINGS LLC

DATE: 04.3.24

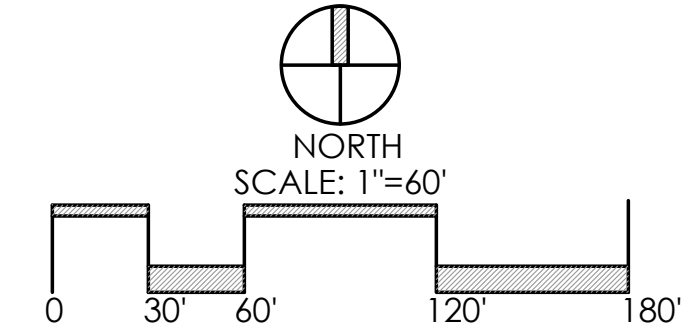
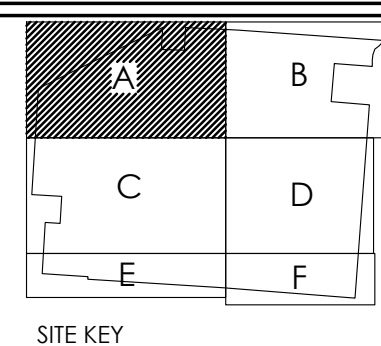

**Faris Planning & Design**

LAND PLANNING      LANDSCAPE ARCHITECTURE  
4876 Cemetery Hilliard, OH 43026  
p. (614) 487-1964      www.farisplanninganddesign.com





**PLANT KEY TYPICALS**  
SEE PLANT LIST FOR SPECIFIC PLANT SPECIES

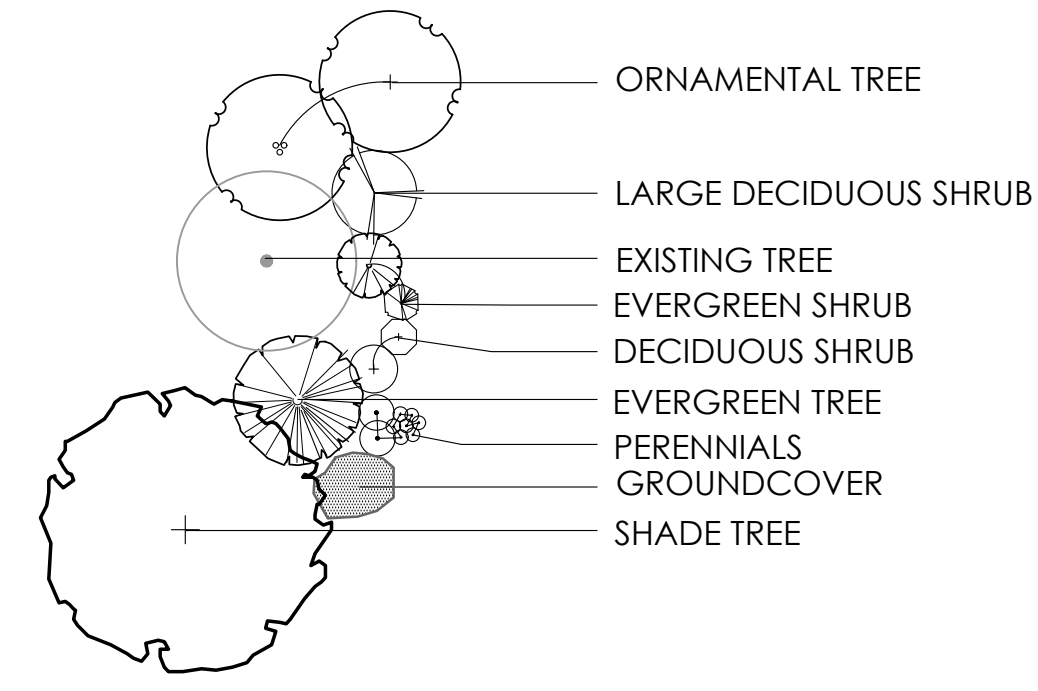

**SITE KEY**

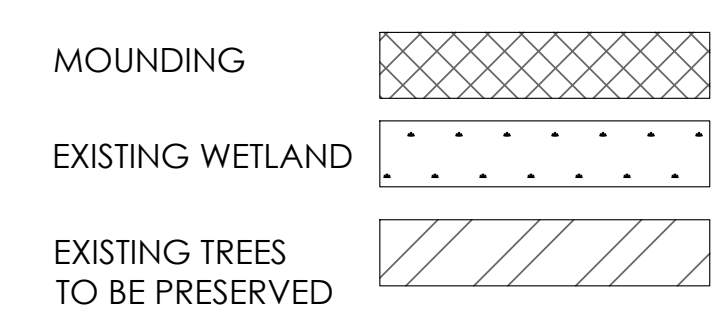

**MINIMUM LANDSCAPE REQUIREMENTS**

MOUND LANDSCAPE	* MIXTURE OF DECIDUOUS, EVERGREEN TREES AND SHRUBS. * MINIMUM OPACITY OF 75% WITHIN 5 YEARS OF PLANTING TO A TOTAL HEIGHT OF AT LEAST 6' ABOVE THE TOP OF THE MOUND.
TREE INSTALLATION SIZE	* TREE SIZE SHALL BE A MIX OF AT LEAST THREE DIFFERENT SIZES RANGING FROM 2-3 CALIPER IN. * NO MORE THAN 50% SHALL BE 2-IN CALIPER.
TREE SPECIES DIVERSITY	* AT LEAST 5 SPECIES PER PROPERTY * ONE SPECIES CAN BE NO MORE THAN 40% OF THE OVERALL QUANTITY. * TREES SHALL BE NATIVE AND FROM REGIONAL NURSERY.
TREE SPACING	* RANDOMLY SPACED IN STAGGERED PATTERN * MINIMUM OF 30 TREES PER 100 LINEAR FEET
UNDERPLANTING	* TREES SHALL BE UNDERPLANTED WITH TURF GRASS AND/OR GROUNDCOVER TO FULLY COVER REMAINDER OF LANDSCAPE AREA.

LANDSCAPE BUFFER PLAN-B

EXHIBIT D-1.2

**FAIR LADY TECHNOLOGY PARK**

PREPARED FOR FAIR LADY DEVELOPMENT HOLDINGS LLC

DATE: 4.3.24

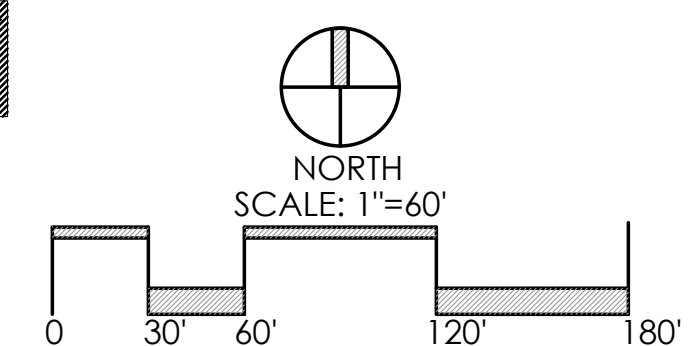
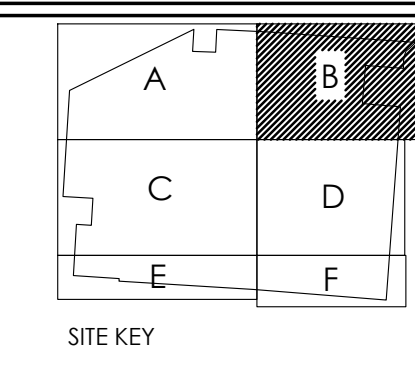

**Faris Planning & Design**

LAND PLANNING      LANDSCAPE ARCHITECTURE  
4876 Cemetery Hilliard, OH 43026  
p. (614) 487-1964      www.farisplanninganddesign.com



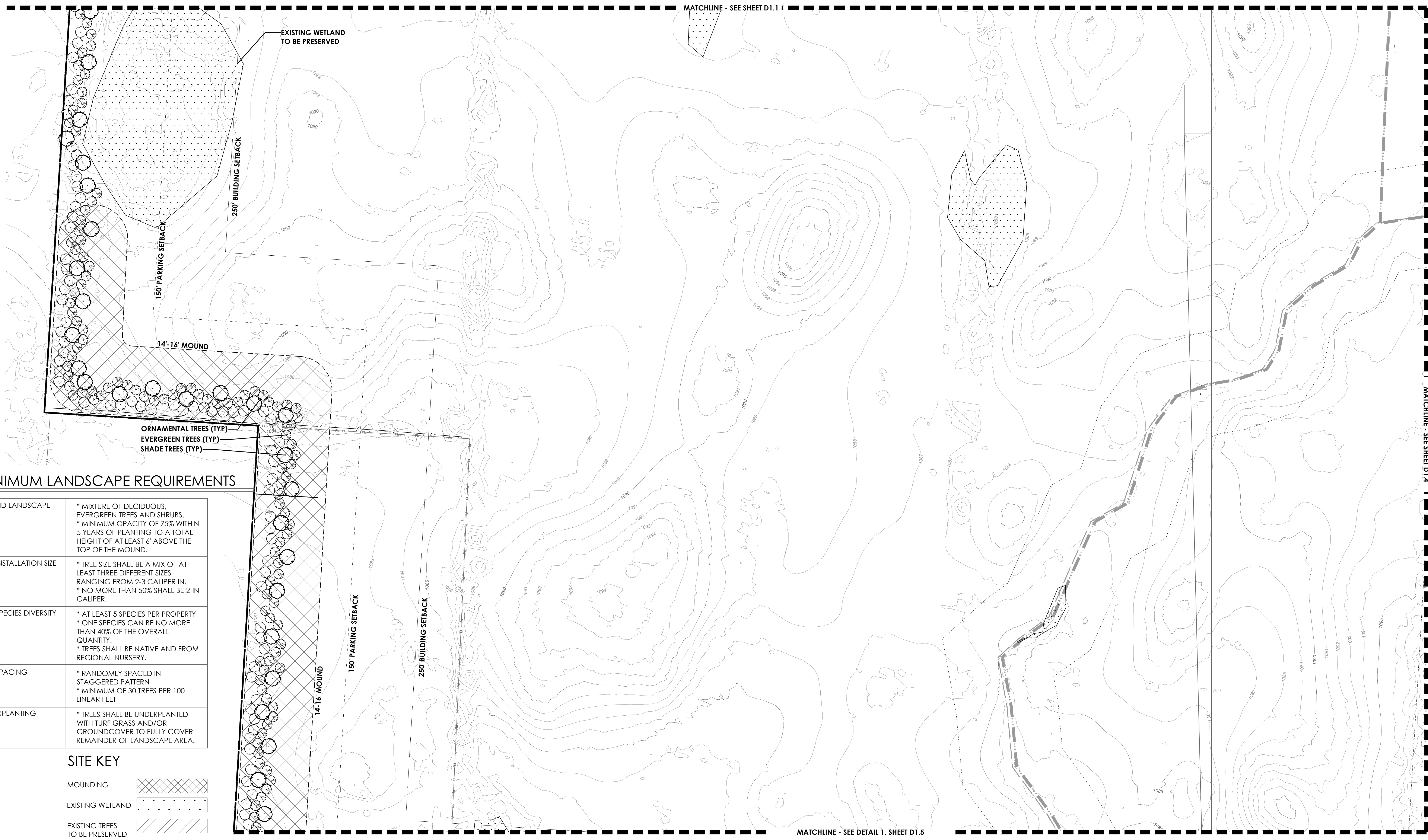

**MINIMUM LANDSCAPE REQUIREMENTS**

MOUND LANDSCAPE	* MIXTURE OF DECIDUOUS, EVERGREEN TREES AND SHRUBS. * MINIMUM OPACITY OF 75% WITHIN 5 YEARS OF PLANTING TO A TOTAL HEIGHT OF AT LEAST 6' ABOVE THE TOP OF THE MOUND.
TREE INSTALLATION SIZE	* TREE SIZE SHALL BE A MIX OF AT LEAST THREE DIFFERENT SIZES RANGING FROM 2-3 CALIPER IN. * NO MORE THAN 50% SHALL BE 2-IN CALIPER.
TREE SPECIES DIVERSITY	* AT LEAST 5 SPECIES PER PROPERTY * ONE SPECIES CAN BE NO MORE THAN 40% OF THE OVERALL QUANTITY. * TREES SHALL BE NATIVE AND FROM REGIONAL NURSERY.
TREE SPACING	* RANDOMLY SPACED IN STAGGERED PATTERN * MINIMUM OF 30 TREES PER 100 LINEAR FEET
UNDERPLANTING	* TREES SHALL BE UNDERPLANTED WITH TURF GRASS AND/OR GROUND COVER TO FULLY COVER REMAINDER OF LANDSCAPE AREA.

**SITE KEY**

- MOUNDING
- EXISTING WETLAND
- EXISTING TREES TO BE PRESERVED

**LANDSCAPE BUFFER PLAN - C**

**EXHIBIT D-1.3**

**FAIR LADY TECHNOLOGY PARK**

PREPARED FOR FAIR LADY DEVELOPMENT HOLDINGS LLC  
DATE: 4.3.24

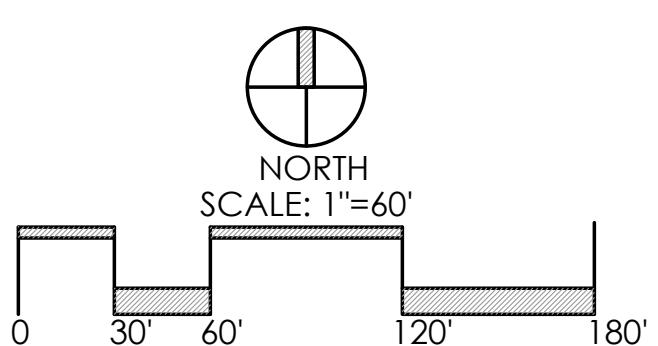
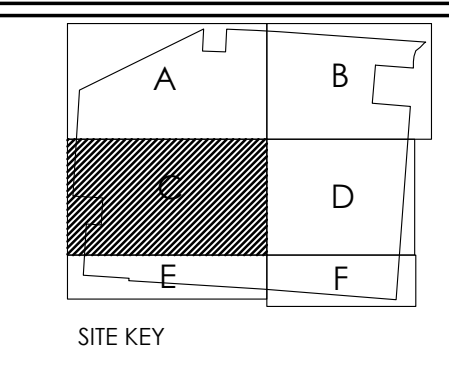

**Faris Planning & Design**

LAND PLANNING      LANDSCAPE ARCHITECTURE  
4876 Cemetery Hilliard, OH 43026  
p. (614) 487-1964      www.farisplanninganddesign.com





### MINIMUM LANDSCAPE REQUIREMENTS

MOUND LANDSCAPE	* MIXTURE OF DECIDUOUS, EVERGREEN TREES AND SHRUBS. * MINIMUM OPACITY OF 75% WITHIN 5 YEARS OF PLANTING TO A TOTAL HEIGHT OF AT LEAST 6' ABOVE THE TOP OF THE MOUND.
TREE INSTALLATION SIZE	* TREE SIZE SHALL BE A MIX OF AT LEAST THREE DIFFERENT SIZES RANGING FROM 2-3 CALIPER IN. * NO MORE THAN 50% SHALL BE 2-IN CALIPER.
TREE SPECIES DIVERSITY	* AT LEAST 5 SPECIES PER PROPERTY * ONE SPECIES CAN BE NO MORE THAN 40% OF THE OVERALL QUANTITY. * TREES SHALL BE NATIVE AND FROM REGIONAL NURSERY.
TREE SPACING	* RANDOMLY SPACED IN STAGGERED PATTERN * MINIMUM OF 30 TREES PER 100 LINEAR FEET
UNDERPLANTING	* TREES SHALL BE UNDERPLANTED WITH TURF GRASS AND/OR GROUNDCOVER TO FULLY COVER REMAINDER OF LANDSCAPE AREA.

### PLANT KEY TYPICALS

SEE PLANT LIST FOR SPECIFIC PLANT SPECIES

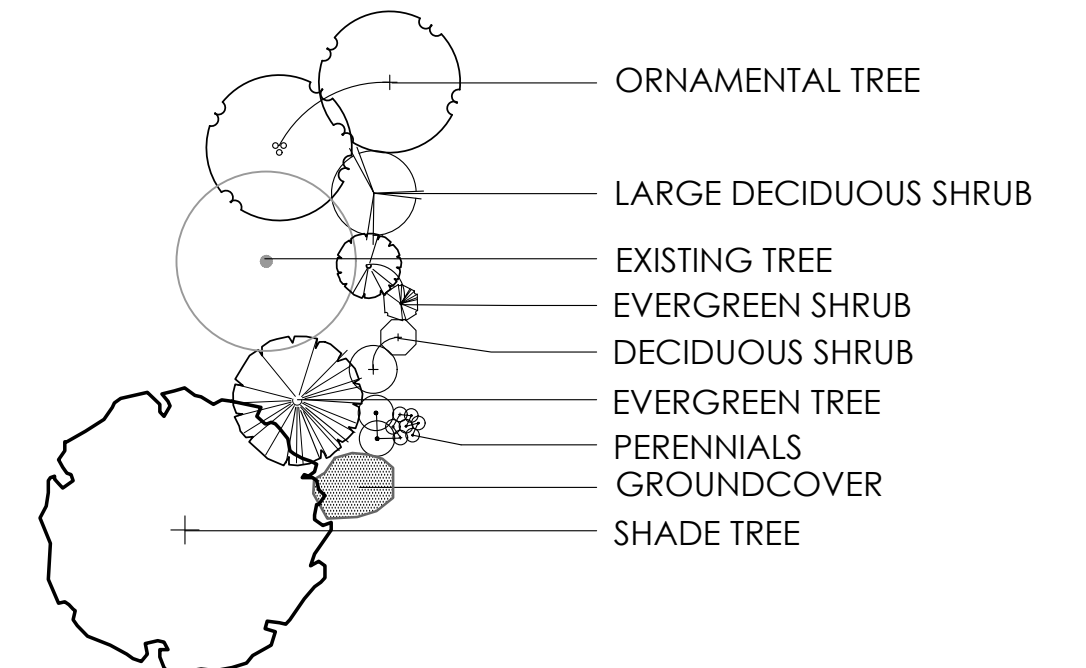

### SITE KEY

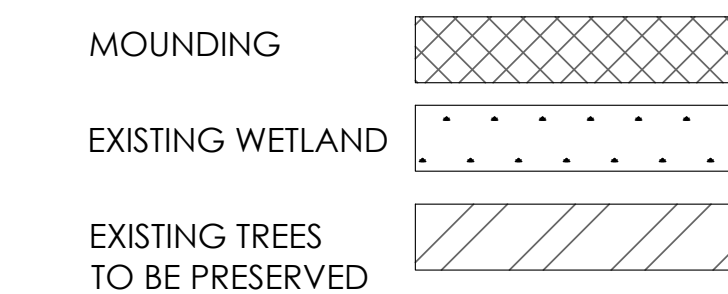

## LANDSCAPE BUFFER PLAN - D

## EXHIBIT D-1.4

# FAIR LADY TECHNOLOGY PARK

PREPARED FOR FAIR LADY DEVELOPMENT HOLDINGS LLC

DATE: 4.3.24

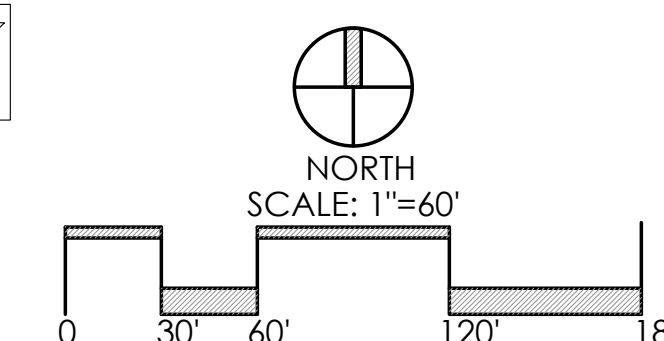
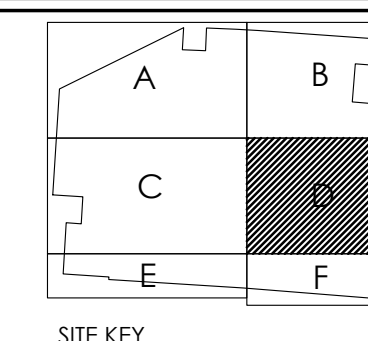

**Faris Planning & Design**

LAND PLANNING  
4876 Cemetery  
p.1614] 487-1964

LANDSCAPE ARCHITECTURE  
Hilliard, OH 43026  
www.farisplanninganddesign.com



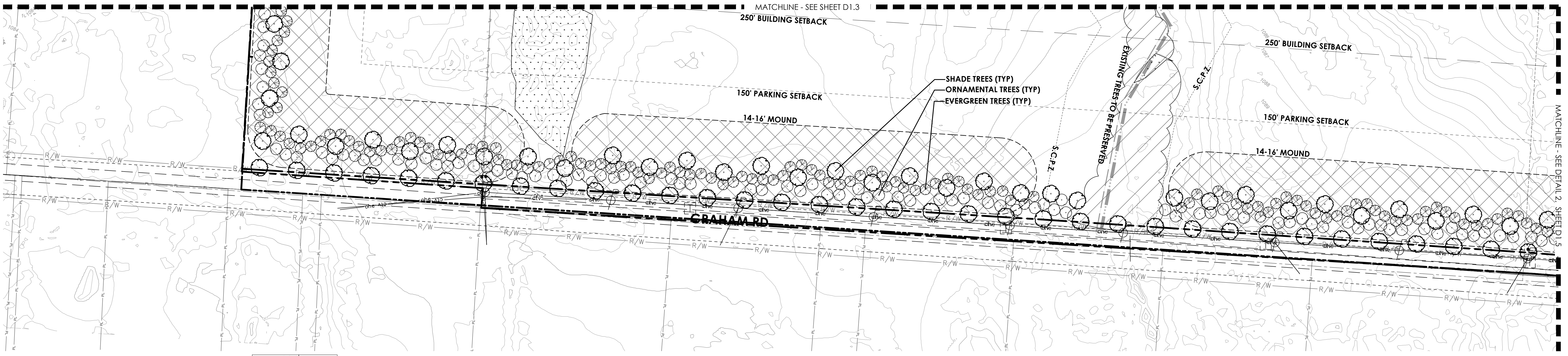

1 LANDSCAPE BUFFER- E  
SCALE: 1:60

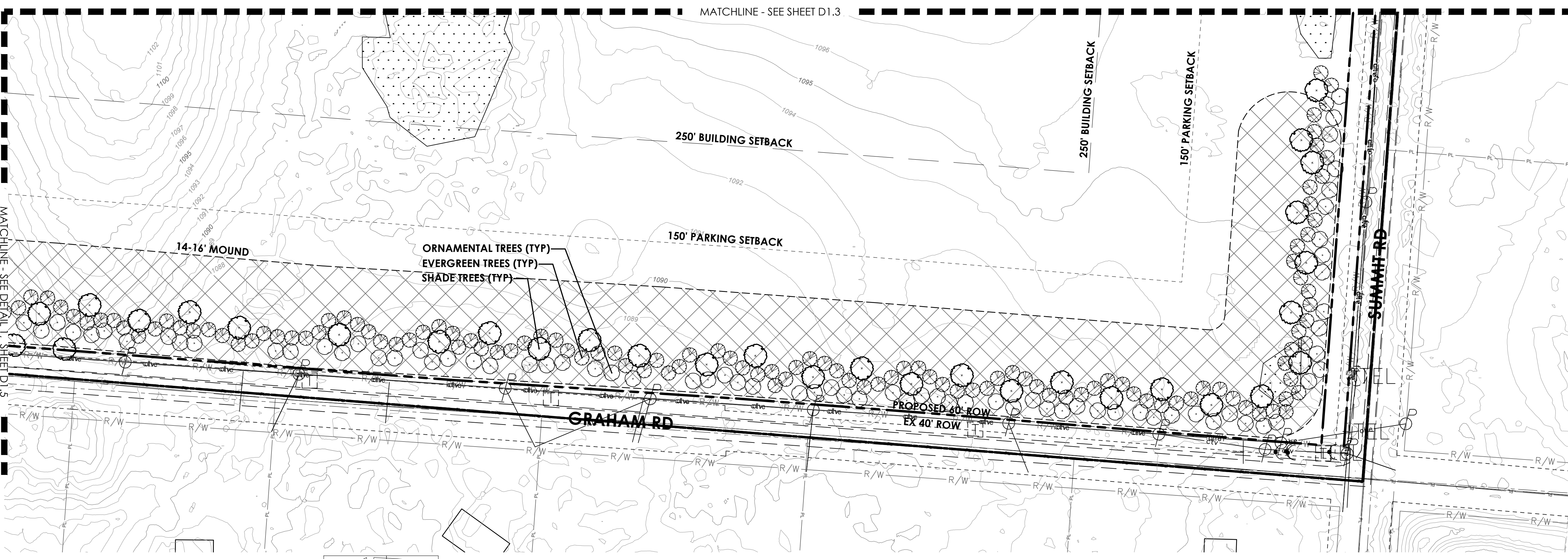

2 LANDSCAPE BUFFER- F  
SCALE: 1:60

MINIMUM LANDSCAPE REQUIREMENTS

MOUND LANDSCAPE	* MIXTURE OF DECIDUOUS, EVERGREEN TREES AND SHRUBS. * MINIMUM OPACITY OF 75% WITHIN 5 YEARS OF PLANTING TO A TOTAL HEIGHT OF AT LEAST 6' ABOVE THE TOP OF THE MOUND.
TREE INSTALLATION SIZE	* TREE SIZE SHALL BE A MIX OF AT LEAST THREE DIFFERENT SIZES RANGING FROM 2-3 CALIPER IN. * NO MORE THAN 50% SHALL BE 2-IN CALIPER.
TREE SPECIES DIVERSITY	* AT LEAST 5 SPECIES PER PROPERTY * ONE SPECIES CAN BE NO MORE THAN 40% OF THE OVERALL QUANTITY. * TREES SHALL BE NATIVE AND FROM REGIONAL NURSERY.
TREE SPACING	* RANDOMLY SPACED IN STAGGERED PATTERN * MINIMUM OF 30 TREES PER 100 LINEAR FEET
UNDERPLANTING	* TREES SHALL BE UNDERPLANTED WITH TURF GRASS AND/OR GROUNDCOVER TO FULLY COVER REMAINDER OF LANDSCAPE AREA.

PLANT KEY TYPICALS  
SEE PLANT LIST FOR SPECIFIC PLANT SPECIES

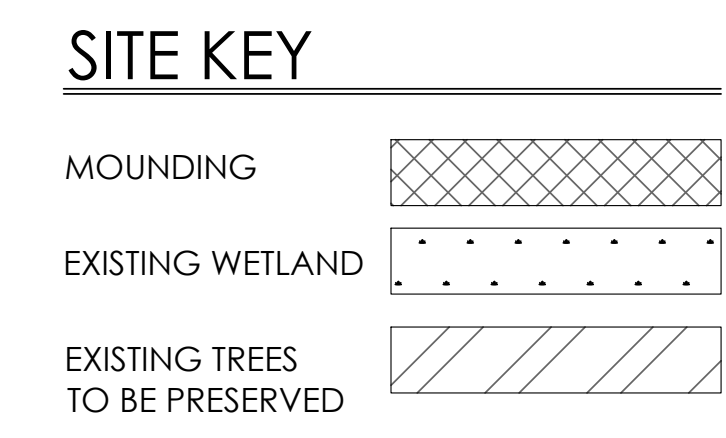
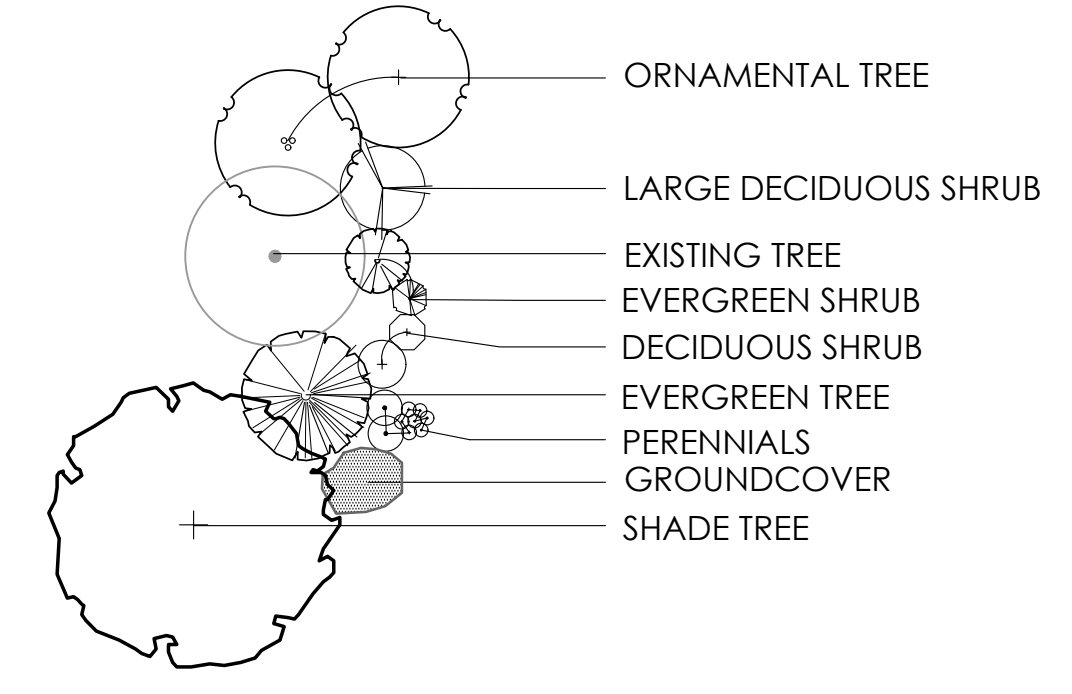

LANDSCAPE BUFFER PLAN - E & F

EXHIBIT D-1.5

FAIR LADY TECHNOLOGY PARK

PREPARED FOR FAIR LADY DEVELOPMENT HOLDINGS LLC  
DATE: 4.3.24

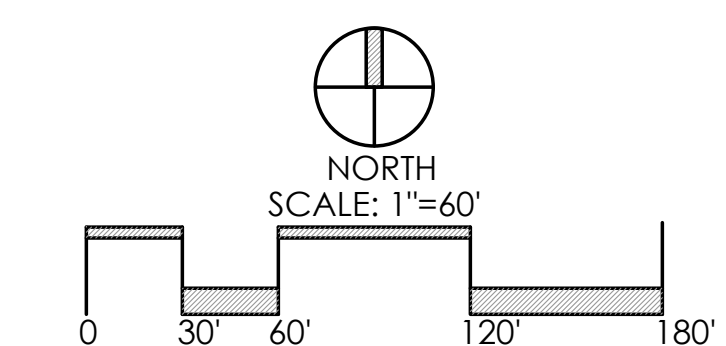



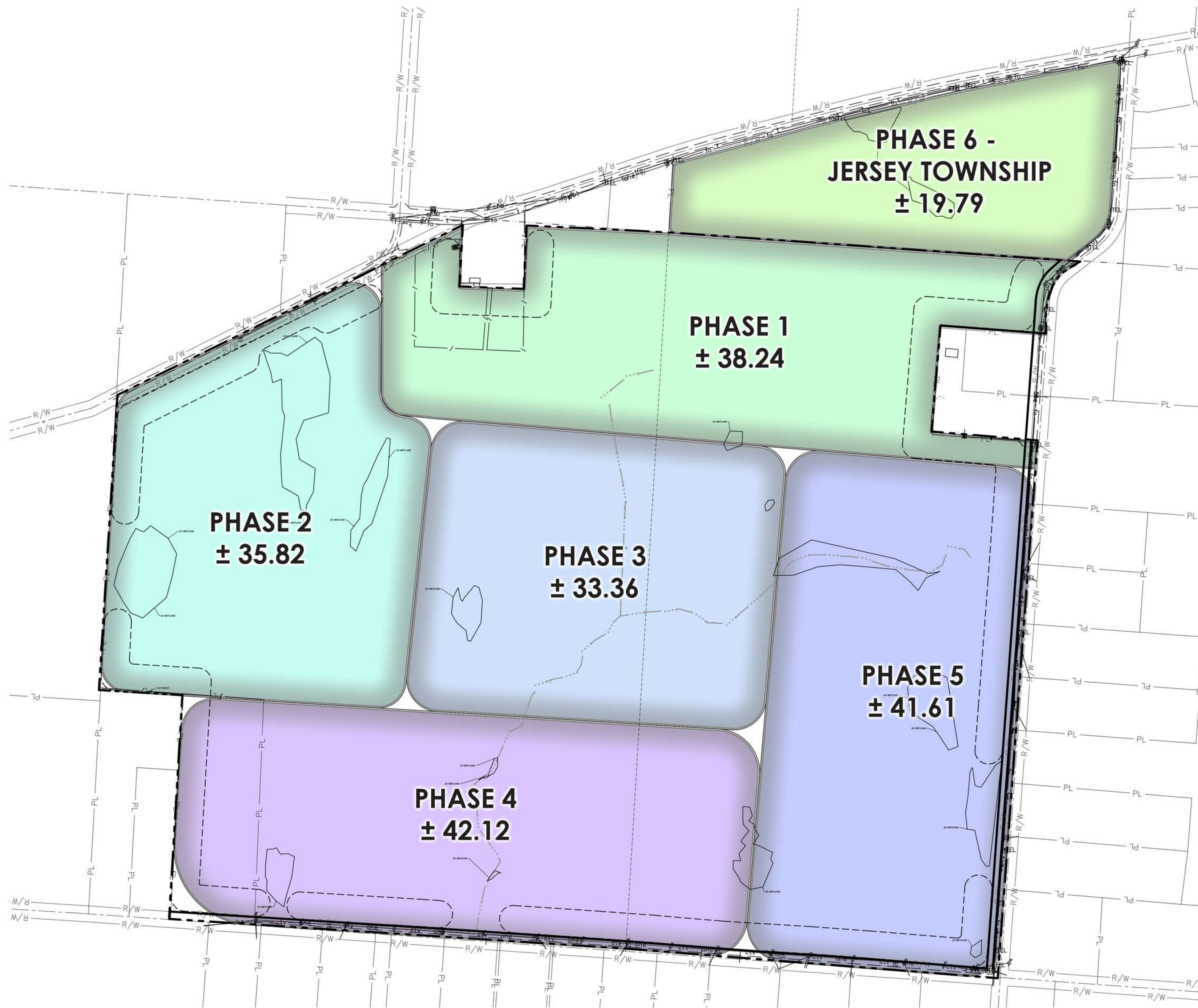

**\*PHASING IS PRELIMINARY ONLY. FINAL ACREAGE AND CONFIGURATION OF PHASES SHALL BE DEPENDENT ON END USER AND SHALL BE DETERMINED AT FINAL DEVELOPMENT LEVEL.**

## PRELIMINARY PHASING PLAN

# FAIR LADY TECHNOLOGY PARK

PREPARED FOR FAIR LADY DEVELOPMENT HOLDINGS LLC

DATE: 4.3.24

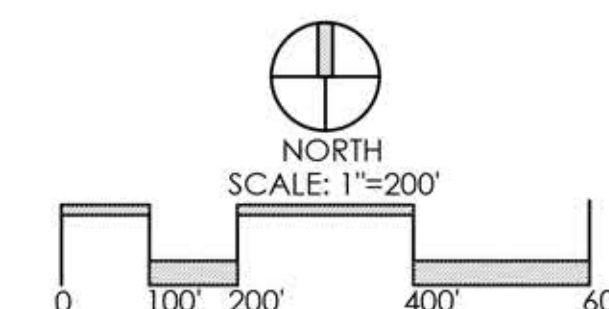

**Faris Planning & Design**

LAND PLANNING LANDSCAPE ARCHITECTURE  
 4876 Cemetery Hilliard, OH 43026  
 p (614) 487-1964 www.farisplanninganddesign.com